

6

Worm geared motors



6/2 6/3	Orientation Overview Modular system
6/4	General technical data Permissible radial force
6/5	Geared motors up to 1,5 kW Selection and ordering data
6/9	Transmission ratios and maximum torques Selection and ordering data
6/11	Mounting types Selection and ordering data
6/13	Shaft designs Selection and ordering data
6/14	Flange-mounted designs Selection and ordering data
6/15	Mounting types and mounting positions Selection and ordering data
6/16 6/16	Special versions Worm gear unit SC for attaching IEC motors (solo gear unit) Second output shaft extension
6/17 6/19	Dimensions Dimension drawing overview Dimension drawings

Geared motors

Worm geared motors

Orientation

Overview

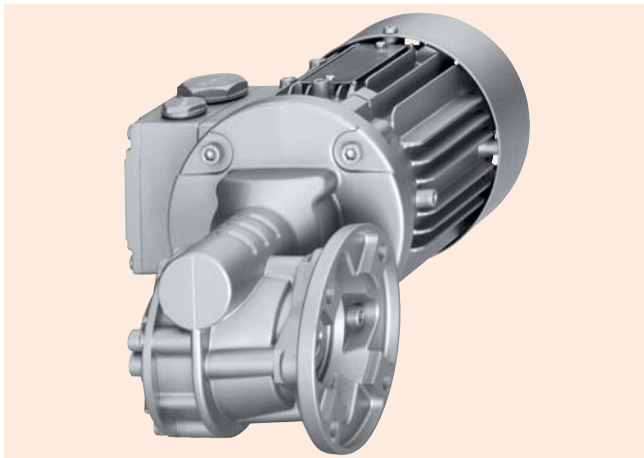

Worm gear units are designated as follows:

Gear unit type:

SC Worm gear unit

Output-side designs

- ① Shaft designs:
- A** Hollow shaft
 - E** Plug-in shaft
 - With one shaft extension (position A or B)
 - With two shaft extensions
- ② Mounting designs:
- C** Foot (position 6 h, 9 h, or 12 h)
 - D** Torque arm (position A or B)
can be mounted in 5 positions
 - F** Flange, A-type (position A or B)
 - Short design
 - Long design
 - Z** Housing flange, C-type, on both sides

Input-side designs

- ③ **K4** Adapter unit with plug-in shaft connection according to:
 - Motor size and mounting position or
 - Flange size and shaft diameter
(additional data required)

Example:

SC ① ② 50 - ③
(basic gear unit = SCAZ50)

The series currently comprises three gear unit sizes.

Worm gear units are available in a single-stage version.

Worm and wheel sets with CAVEX gearing

The concave-profile cylindrical worm with its enveloping worm wheel is very much different to conventional designs. The worm threads have a concave profile instead of an involute or convex one.

The concave-profile teeth are subject to only low specific tooth pressure. The retention of a separating oil film between the tooth flanks is facilitated in particular, as the hollow flanks are in contact with convex mating flanks. Therefore, profile contact is much more favorable than in conventional gear teeth systems.

The concave-profile teeth provide a particularly favorable position for the instantaneous axes, which extend mainly at right angles to the sliding direction. This assists the build-up of lubricating pressure, i.e. the generation of an oil film between the tooth flanks.

The tooth flanks on new gear units will not yet be fully smoothed, meaning that the friction angle will be greater and efficiency lower during initial operation. The smaller the lead angle or, in other words, the higher the transmission ratio, the more pronounced the effect. The run-in procedure should take approximately 24 to 30 hours of operation at full load.

Starting efficiency is never as great as the efficiency at operating speed. This fact should be taken into account when starting a machine at full load, depending on the starting characteristics of the motor.

Notice: In respect of torque driving back from the output shaft, please take into account the reduced gear tooth efficiency $\eta' = 2 - 1/\eta$, particularly with high transmission ratios of the worm gear stage (η = efficiency with driving worm).

Modular system

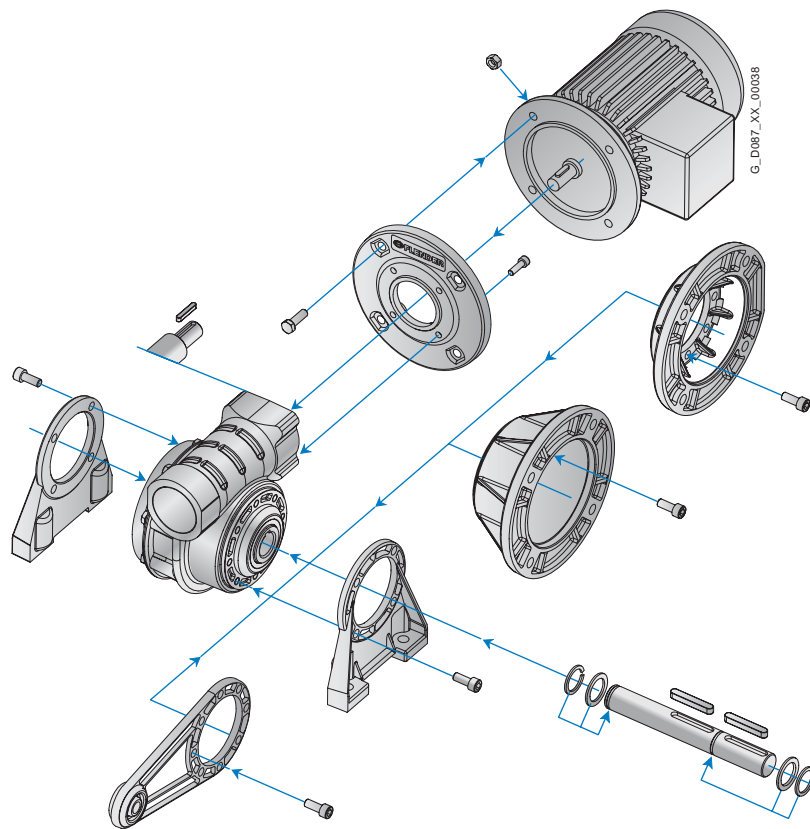

SC = Basic gear unit with housing flanges (C-type)

Output-side variants		Output-side variants	
M	= Motor (IM B14* or IM B5)	C	= 2 feet
K4	= Adapter flange* for IEC standard motors (IM B14 or IM B5)	FK	= Short flange (A-type)*
		FL	= Long flange (A-type)*
		E1	= Plug-in shaft with one shaft extension**
		E2	= Plug-in shaft with two shaft extensions**
		D	= Torque arm**

* These modules are mounted at the factory prior to delivery, in accordance with the order.

** These modules are not mounted prior to delivery in order to provide greater flexibility during installation.

Use

MOTOX worm gear units are characterized by high throughput in a very small space and a high transmission ratio in a single stage. Thanks to their compact design, worm gear units are an ideal solution when installation space is at a premium and they offer a range of mounting options due to their flange, foot, and torque-arm housing designs.

Output shafts are available in different versions and diameters, as solid or hollow shafts. The gear unit housings, made from die-cast aluminum with good thermal conductivity, are strong and absorb vibrations.

Geared motors

Worm geared motors

General technical data

Permissible radial force F_{xperm1} and F_{xperm2}

Gear unit type	d mm	l mm	y mm	z mm	a kNmm	b mm	F_{Rperm} in N with $x = l/2$ for input speeds n_2 in rpm					
							≤ 25	≤ 40	≤ 63	≤ 100	≤ 163	≤ 250
SC36	18	40	81.5	61.5	48.5	2.0	3000	3000	2600	2100	1700	1400
SC50	25	50	98.0	73.0	110.0	2.5	4400	4100	3300	2700	2100	1600
SC63	25	60	134.0	104.0	120.0	2.5	5000	4500	3400	2800	2200	1700

Geared motors

Worm geared motors

Geared motors up to 1.5 kW

Selection and ordering data

The selection tables show the most common variants and combinations. Other combinations can be selected using our MOTOX Configurator or made available on request.

At an identical power and output speed, priority is given in the selection tables to 4-pole geared motors.

At the available transmission ratios, they cover the majority of output speeds.

Due to their prevalence, 4-pole geared motors are easily available, with short delivery times and at a low cost. They also feature a favorable size / power ratio.

Power P_{motor} kW	Output speed		Output torque T_2 Nm	Service factor f_B	Gear ratio i_{tot}	Efficiency η	Order number	Order code (No. of poles)	Weight kg
	n_2 (50 Hz) rpm	n_2 (60 Hz) rpm							
0.09 (50 Hz)	SC.63-LAI71M8								
0.11 (60 Hz)	6.3	7.6	74	1.8	100	0.54	2KJ1702 - ■ CE13 - ■ L1-Z	P02	12
	SC.50-LAI71M8								
	7.9	9.5	59	1.4	80	0.54	2KJ1701 - ■ CE13 - ■ K1-Z	P02	10
	SC.50-LAI71B6								
	11.1	13.3	42	1.9	80	0.54	2KJ1701 - ■ CB13 - ■ K1-Z	P01	10
	SC.36-LAI71M8								
	15.8	19.0	37	1.2	40	0.68	2KJ1700 - ■ CE13 - ■ G1-Z	P02	8
	21.0	25.0	29	1.4	30	0.71	2KJ1700 - ■ CE13 - ■ F1-Z	P02	8
	SC.36-LAI71B6								
	22.0	26.0	26	1.6	40	0.68	2KJ1700 - ■ CB13 - ■ G1-Z	P01	8
	30.0	36.0	21	2.0	30	0.71	2KJ1700 - ■ CB13 - ■ F1-Z	P01	8
0.12 (50 Hz)	SC.63-LAI71MB8								
0.14 (60 Hz)	6.4	7.7	96	1.4	100	0.54	2KJ1702 - ■ CF13 - ■ L1-Z	P02	12
	SC.63-LAI71C6								
	8.6	10.3	72	1.8	100	0.54	2KJ1702 - ■ CC13 - ■ L1-Z	P01	12
	SC.50-LAI71MB8								
	8.1	9.7	77	1.0	80	0.54	2KJ1701 - ■ CF13 - ■ K1-Z	P02	10
	SC.50-LAI71C6								
	10.8	13.0	58	1.4	80	0.54	2KJ1701 - ■ CC13 - ■ K1-Z	P01	10
	14.3	17.2	47	1.7	60	0.59	2KJ1701 - ■ CC13 - ■ J1-Z	P01	10
	SC.50-LAI71B4								
	16.9	20	37	2.2	80	0.54	2KJ1701 - ■ CB13 - ■ K1		10
	SC.36-LAI71MB8								
	16.1	19.3	48	0.89	40	0.68	2KJ1700 - ■ CF13 - ■ G1-Z	P01	8
	SC.36-LAI71C6								
	22	26	36	1.2	40	0.68	2KJ1700 - ■ CC13 - ■ G1-Z	P01	8
	29	35	28	1.4	30	0.71	2KJ1700 - ■ CC13 - ■ F1-Z	P01	8
	SC.36-LAI71B4								
	34	41	23	1.9	40	0.68	2KJ1700 - ■ CB13 - ■ G1		8
	45	54	18	2.3	30	0.71	2KJ1700 - ■ CB13 - ■ F1		8
	54	65	16	2.6	25	0.74	2KJ1700 - ■ CB13 - ■ E1		8
	68	82	14	2.9	20	0.82	2KJ1700 - ■ CB13 - ■ D1		8
0.18 (50 Hz)	SC.63-LAI71S6								
0.22 (60 Hz)	8.4	10.1	111	1.2	100	0.54	2KJ1702 - ■ CD13 - ■ L1-Z	P01	12
	10.4	12.5	100	1.7	80	0.61	2KJ1702 - ■ CD13 - ■ K1-Z	P01	12

Shaft designs, see page 6/13

Frequency and voltage, see page 8/15

Gear unit housing mounting position, see page 6/11

1, 5 or 6

1 to 9

A, D, F, or H

Geared motors

Worm geared motors

Geared motors up to 1.5 kW

Selection and ordering data (continued)

Power P_{motor} kW	Output speed		Output torque T_2 Nm	Service factor f_B	Gear ratio i_{tot}	Efficiency η	Order number	Order code (No. of poles)	Weight kg
	n_2 (50 Hz) rpm	n_2 (60 Hz) rpm							
0.18 (50 Hz) 0.22 (60 Hz)	SC.63-LAI71C4								
	13.5	16.2	69	1.9	100	0.54	2KJ1702 - ■ CC13 - ■ ■ L1		12
	SC.50-LAI71S6								
	10.4	12.5	89	0.9	80	0.54	2KJ1701 - ■ CD13 - ■ ■ K1-Z	P01	10
	13.9	16.7	73	1.1	60	0.59	2KJ1701 - ■ CD13 - ■ ■ J1-Z	P01	10
	SC.50-LAI71C4								
	16.9	20	55	1.5	80	0.54	2KJ1701 - ■ CC13 - ■ ■ K1		10
	22.0	26	45	1.7	60	0.59	2KJ1701 - ■ CC13 - ■ ■ J1		10
	27.0	32	40	1.9	50	0.62	2KJ1701 - ■ CC13 - ■ ■ H1		10
	34.0	41	33	2.2	40	0.65	2KJ1701 - ■ CC13 - ■ ■ G1		10
	45.0	54	26	2.8	30	0.69	2KJ1701 - ■ CC13 - ■ ■ F1		10
	SC.36-LAI71S6								
	28	34	44	0.94	30	0.71	2KJ1700 - ■ CD13 - ■ ■ F1-Z	P01	8
	SC.36-LAI71C4								
	34	41	35	1.2	40	0.68	2KJ1700 - ■ CC13 - ■ ■ G1		8
	45	54	27	1.5	30	0.71	2KJ1700 - ■ CC13 - ■ ■ F1		8
	54	65	24	1.7	25	0.74	2KJ1700 - ■ CC13 - ■ ■ E1		8
	68	82	21	2.0	20	0.82	2KJ1700 - ■ CC13 - ■ ■ D1		8
	90	108	16	2.6	15	0.84	2KJ1700 - ■ CC13 - ■ ■ C1		8
135	162	11	3.6	10	0.88	2KJ1700 - ■ CC13 - ■ ■ B1		8	
0.25 (50 Hz) 0.30 (60 Hz)	SC.63-LAI71M6								
	8.3	10.0	155	0.86	100	0.54	2KJ1702 - ■ CE13 - ■ ■ L1-Z	P01	12
	10.4	12.5	140	1.20	80	0.61	2KJ1702 - ■ CE13 - ■ ■ K1-Z	P01	12
	SC.63-LAI71S4								
	13.5	16.2	96	1.4	100	0.54	2KJ1702 - ■ CD13 - ■ ■ L1		12
	16.9	20.0	86	1.9	80	0.61	2KJ1702 - ■ CD13 - ■ ■ K1		12
	22.0	26.0	70	2.3	60	0.66	2KJ1702 - ■ CD13 - ■ ■ J1		12
	SC.50-LAI71S4								
	16.9	20	76	1.0	80	0.54	2KJ1701 - ■ CD13 - ■ ■ K1		10
	22.0	26	63	1.2	60	0.59	2KJ1701 - ■ CD13 - ■ ■ J1		10
	27.0	32	55	1.4	50	0.62	2KJ1701 - ■ CD13 - ■ ■ H1		10
	34.0	41	46	1.6	40	0.65	2KJ1701 - ■ CD13 - ■ ■ G1		10
	45.0	54	37	2.0	30	0.69	2KJ1701 - ■ CD13 - ■ ■ F1		10
	54.0	65	31	2.3	25	0.71	2KJ1701 - ■ CD13 - ■ ■ E1		10
	68.0	82	28	2.6	20	0.79	2KJ1701 - ■ CD13 - ■ ■ D1		10
	90.0	108	22	3.3	15	0.82	2KJ1701 - ■ CD13 - ■ ■ C1		10
	SC.36-LAI71S4								
	34	41	48	0.89	40	0.68	2KJ1700 - ■ CD13 - ■ ■ G1		8
	45	54	38	1.10	30	0.71	2KJ1700 - ■ CD13 - ■ ■ F1		8
	54	65	33	1.30	25	0.74	2KJ1700 - ■ CD13 - ■ ■ E1		8
	68	82	29	1.40	20	0.82	2KJ1700 - ■ CD13 - ■ ■ D1		8
	90	108	22	1.80	15	0.84	2KJ1700 - ■ CD13 - ■ ■ C1		8
	135	162	16	2.60	10	0.88	2KJ1700 - ■ CD13 - ■ ■ B1		8
	193	232	11	3.60	7	0.91	2KJ1700 - ■ CD13 - ■ ■ A1		8

Shaft designs, see page 6/13

1, 5 or 6

Frequency and voltage, see page 8/15

1 to 9

Gear unit housing mounting position, see page 6/11

A, D, F, or H

Geared motors

Worm geared motors

Geared motors up to 1.5 kW

Selection and ordering data (continued)

Power P_{motor} kW	Output speed		Output torque T_2 Nm	Service factor f_B	Gear ratio i_{tot}	Efficiency η	Order number	Order code (No. of poles)	Weight kg
	n_2 (50 Hz) rpm	n_2 (60 Hz) rpm							
0.37 (50 Hz)	SC.63-LAI80S6								
0.44 (60 Hz)	11.5	13.8	187	0.89	80	0.61	2KJ1702 - ■ DB13 - ■■ K1-Z	P01	16
	SC.63-LAI71M4								
	13.7	16.4	139	0.95	100	0.54	2KJ1702 - ■ CE13 - ■■ L1		12
	17.1	21.0	126	1.30	80	0.61	2KJ1702 - ■ CE13 - ■■ K1		12
	23.0	28.0	102	1.60	60	0.66	2KJ1702 - ■ CE13 - ■■ J1		12
	27.0	32.0	88	1.80	50	0.68	2KJ1702 - ■ CE13 - ■■ H1		12
	34.0	41.0	73	2.20	40	0.71	2KJ1702 - ■ CE13 - ■■ G1		12
	46.0	55.0	57	2.70	30	0.74	2KJ1702 - ■ CE13 - ■■ F1		12
	SC.50-LAI71M4								
	23	28	91	0.85	60	0.59	2KJ1701 - ■ CE13 - ■■ J1		10
	27	32	80	0.94	50	0.62	2KJ1701 - ■ CE13 - ■■ H1		10
	34	41	67	1.10	40	0.65	2KJ1701 - ■ CE13 - ■■ G1		10
	46	55	53	1.40	30	0.69	2KJ1701 - ■ CE13 - ■■ F1		10
	55	66	46	1.60	25	0.71	2KJ1701 - ■ CE13 - ■■ E1		10
	68	82	41	1.80	20	0.79	2KJ1701 - ■ CE13 - ■■ D1		10
	91	109	32	2.30	15	0.82	2KJ1701 - ■ CE13 - ■■ C1		10
	137	164	22	3.20	10	0.87	2KJ1701 - ■ CE13 - ■■ B1		10
	196	235	16	4.30	7	0.91	2KJ1701 - ■ CE13 - ■■ A1		10
	SC.36-LAI71M4								
	55	66	48	0.86	25	0.74	2KJ1700 - ■ CE13 - ■■ E1		8
	68	82	42	0.97	20	0.82	2KJ1700 - ■ CE13 - ■■ D1		8
	91	109	32	1.30	15	0.84	2KJ1700 - ■ CE13 - ■■ C1		8
	137	164	23	1.80	10	0.88	2KJ1700 - ■ CE13 - ■■ B1		8
	196	235	16	2.40	7	0.91	2KJ1700 - ■ CE13 - ■■ A1		8
0.55 (50 Hz)	SC.63-LAI90LA8								
0.66 (60 Hz)	45	54	99	1.5	15	0.85	2KJ1702 - ■ EE13 - ■■ C1	P02	22
	SC.63-LAI80M6								
	11.4	13.7	282	0.59	80	0.61	2KJ1702 - ■ DC13 - ■■ K1	P01	16
	15.2	18.2	229	0.72	60	0.66	2KJ1702 - ■ DC13 - ■■ J1	P01	16
	36.0	43.0	110	1.40	25	0.76	2KJ1702 - ■ DC13 - ■■ E1	P01	16
	46.0	55.0	96	1.60	20	0.83	2KJ1702 - ■ DC13 - ■■ D1	P01	16
	61.0	73.0	74	2.10	15	0.85	2KJ1702 - ■ DC13 - ■■ C1	P01	16
	SC.50-LAI80M6								
	36	43	102	0.71	25	0.71	2KJ1701 - ■ DC13 - ■■ E1	P01	14
	46	55	91	0.80	20	0.79	2KJ1701 - ■ DC13 - ■■ D1	P01	14
	61	73	71	1.00	15	0.82	2KJ1701 - ■ DC13 - ■■ C1	P01	14
0.75 (50 Hz)	SC.63-LAI80M4								
0.90 (60 Hz)	23	28	203	0.81	60	0.66	2KJ1702 - ■ DC13 - ■■ J1		16
	28	34	175	0.92	50	0.68	2KJ1702 - ■ DC13 - ■■ H1		16
	35	42	146	1.10	40	0.71	2KJ1702 - ■ DC13 - ■■ G1		16
	46	55	114	1.30	30	0.74	2KJ1702 - ■ DC13 - ■■ F1		16
	56	67	98	1.60	25	0.76	2KJ1702 - ■ DC13 - ■■ E1		16

Shaft designs, see page 6/13

1, 5 or 6

Frequency and voltage, see page 8/15

1 to 9

Gear unit housing mounting position, see page 6/11

A, D, F, or H

Geared motors

Worm geared motors

Geared motors up to 1.5 kW

Selection and ordering data (continued)

Power P_{motor} kW	Output speed		Output torque T_2 Nm	Service factor f_B	Gear ratio i_{tot}	Efficiency η	Order number	Order code (No. of poles)	Weight kg
	n_2 (50 Hz) rpm	n_2 (60 Hz) rpm							
0.75 (50 Hz)	SC.63-LAI80M4								
0.90 (60 Hz)	70	84	85	1.8	20	0.83	2KJ1702 - DC13 - D1		16
	93	112	66	2.3	15	0.85	2KJ1702 - DC13 - C1		16
	140	168	46	3.2	10	0.90	2KJ1702 - DC13 - B1		16
	SC.50-LAI80M4								
	56	67	91	0.8	25	0.71	2KJ1701-.DC13 - E1		14
	70	84	81	0.9	20	0.79	2KJ1701-.DC13 - D1		14
	93	112	63	1.1	15	0.82	2KJ1701-.DC13 - C1		14
	140	168	45	1.6	10	0.87	2KJ1701-.DC13 - B1		14
	199	239	33	2.2	7	0.91	2KJ1701-.DC13 - A1		14
1.1 (50 Hz)	SC.63-LAI90S4								
1.3 (60 Hz)	47	56	165	0.93	30	0.74	2KJ1702 - EL13 - F1		19
	57	68	141	1.10	25	0.76	2KJ1702 - EL13 - E1		19
	71	85	123	1.20	20	0.83	2KJ1702 - EL13 - D1		19
	94	113	95	1.60	15	0.85	2KJ1702 - EL13 - C1		19
	142	170	67	2.20	10	0.90	2KJ1702 - EL13 - B1		19
	202	242	48	3.10	7	0.92	2KJ1702 - EL13 - A1		19
1.5 (50 Hz)	SC.63-LAI90L4								
1.8 (60 Hz)	71	85	167	0.91	20	0.83	2KJ1702 - EP13 - D1		22
	95	114	129	1.20	15	0.85	2KJ1702 - EP13 - C1		22
	142	170	91	1.70	10	0.90	2KJ1702 - EP13 - B1		22
	203	244	65	2.30	7	0.92	2KJ1702 - EP13 - A1		22

Shaft designs, see page 6/13 ————— **1, 5 or 6**

Frequency and voltage, see page 8/15 ————— **1 to 9**

Gear unit housing mounting position, see page 6/11 ————— **A, D, F, or H**

Geared motors

Worm geared motors

Transmission ratios and maximum torques

Selection and ordering data

Gear unit size	Ratio code Order No. 15th and 16th position	Gear ratio i_{tot}	Lead angle of the worm γ_m approx.: °	Output speed $n_1=2,800$ rpm				Output speed $n_1=1,400$ rpm				IEC motor size				
				n_2	T_2	P_{1N}	η	n_2	T_2	P_{1N}	η	63	71	80	90	
				rpm	Nm	kW	%	rpm	Nm	kW	%					
SC36	J1	60	3.5	46	33	0.24	67	23	42	0.16	62	•				
	H1	50	4.0	56	33	0.28	70	28	44	0.20	65	•				
	G1	40	4.5	70	31	0.32	72	35	43	0.23	68	•	•			
	F1	30	5.5	94	31	0.40	76	47	41	0.28	71	•	•			
	E1	25	6.5	112	31	0.47	78	56	41	0.32	74	•	•			
	D1	20	9.5	142	31	0.54	85	71	41	0.37	82	•	•			
	C1	15	11.0	188	30	0.69	87	94	41	0.48	84	•	•			
	B1	10	17.0	282	30	0.97	91	141	40	0.67	88	•	•			
	A1	7	23.0	402	30	1.36	93	201	40	0.93	91	•	•			
SC50	L1	100	2.0	28	57	0.30	55	14	72	0.22	48	•	•			
	K1	80	2.5	34	57	0.35	59	17	80	0.26	54	•	•			
	J1	60	3.0	46	57	0.43	64	23	78	0.32	59	•	•			
	H1	50	3.5	56	55	0.49	66	28	75	0.35	62	•	•			
	G1	40	4.5	70	55	0.58	70	35	74	0.42	65	•	•			
	F1	30	5.0	94	53	0.71	73	47	73	0.52	69	•	•	•		
	E1	25	6.0	112	53	0.83	75	56	73	0.60	71	•	•	•		
	D1	20	8.5	142	53	0.95	83	71	73	0.69	79	•	•	•		
	C1	15	10.0	188	53	1.24	85	94	72	0.86	82	•	•	•		
	B1	10	15.0	282	53	1.75	90	141	72	1.22	87	•	•	•		
	A1	7	21.0	402	53	2.39	93	201	71	1.64	91	•	•	•		
SC63	L1	100	2.5	28	131	0.60	64	14	133	0.36	54		•			
	K1	80	3.0	34	131	0.70	67	17	166	0.48	61		•	•		
	J1	60	4.0	46	130	0.87	72	23	164	0.60	66		•	•		
	H1	50	4.5	56	128	1.01	74	28	161	0.69	68		•	•		
	G1	40	5.0	70	123	1.19	76	35	159	0.82	71		•	•		
	F1	30	6.0	94	120	1.50	79	47	153	1.02	74		•	•	•	
	E1	25	7.0	112	120	1.74	81	56	152	1.17	76		•	•	•	
	D1	20	10.0	142	120	2.05	87	71	152	1.36	83		•	•	•	
	C1	15	12.0	180	120	2.65	89	94	152	1.76	85		•	•	•	
	B1	10	18.0	282	120	3.81	93	141	150	2.46	90		•	•	•	
	A1	7	24.0	402	117	5.24	94	201	148	3.39	92		•	•	•	

Geared motors

Worm geared motors

Transmission ratios and maximum torques

Selection and ordering data (continued)

Gear unit size	Ratio code	Gear ratio i_{tot}	Lead angle of the worm γ_m approx.: °	Output speed $n_1=900$ rpm				Output speed $n_1=500$ rpm				IEC motor size				
	Order No. 11th position			n_2 rpm	T_2 Nm	P_{1N} kW	η %	n_2 rpm	T_2 Nm	P_{1N} kW	η %	63	71	80	90	
SC36	J1	60	3.5	15	51	0.13	60	8.3	51	0.08	55	•				
	H1	50	4.0	18	51	0.15	63	10	59	1.10	59	•				
	G1	40	4.5	23	51	0.19	66	13	64	0.14	63	•	•			
	F1	30	5.5	30	50	0.22	70	17	63	0.17	67	•	•			
	E1	25	6.5	36	50	0.27	71	20	62	0.19	69	•	•			
	D1	20	9.5	45	50	0.29	80	25	62	0.21	78	•	•			
	C1	15	11.0	60	50	0.38	82	33	62	0.27	80	•	•			
	B1	10	17.0	90	49	0.53	87	50	61	0.38	85	•	•			
	A1	7	23.0	129	48	0.72	90	71	58	0.48	89	•	•			
SC50	L1	100	2.0	9	72	0.16	43	5.0	72	0.10	38	•				
	K1	80	2.5	11	93	0.21	51	6.3	93	0.13	46	•	•			
	J1	60	3.0	15	93	0.26	57	8.3	116	0.19	54	•	•			
	H1	50	3.5	18	90	0.29	59	10.0	115	0.22	56	•	•			
	G1	40	4.5	23	90	0.34	63	13.0	113	0.26	60	•	•			
	F1	30	5.0	30	86	0.41	66	17.0	110	0.31	64	•	•	•		
	E1	25	6.0	36	85	0.46	69	20.0	109	0.35	66	•	•	•		
	D1	20	8.5	45	85	0.52	77	25.0	109	0.38	75	•	•	•		
	C1	15	10.0	60	85	0.67	80	33.0	109	0.48	78	•	•	•		
	B1	10	15.0	90	85	0.94	86	50.0	109	0.68	84	•	•	•		
	A1	7	21.0	129	84	1.28	89	71.0	107	0.90	88	•	•	•		
SC63	L1	100	2.5	9	134	0.26	49	5.0	134	0.16	44		•			
	K1	80	3.0	11	184	0.37	57	6.3	185	0.23	52		•	•		
	J1	60	4.0	15	185	0.46	63	8.3	231	0.33	60		•	•		
	H1	50	4.5	18	183	0.53	65	10.0	224	0.38	62		•	•		
	G1	40	5.0	23	181	0.64	68	13.0	220	0.47	64		•	•		
	F1	30	6.0	30	176	0.78	71	17.0	216	0.57	68		•	•	•	
	E1	25	7.0	36	175	0.90	73	20.0	212	0.63	70		•	•	•	
	D1	20	10.0	45	175	1.02	81	25.0	212	0.70	79		•	•	•	
	C1	15	12.0	60	175	1.32	83	33.0	212	0.90	81		•	•	•	
	B1	10	18.0	90	175	1.87	88	50.0	212	1.29	86		•	•	•	
	A1	7	24.0	129	170	2.52	91	71.0	205	1.71	89		•	•	•	

Selection and ordering data

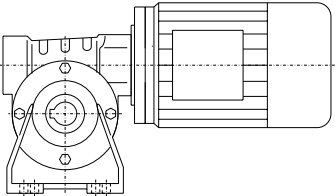
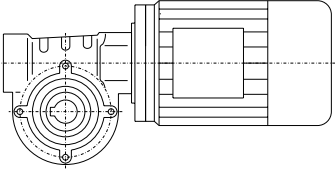
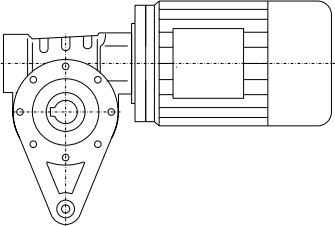
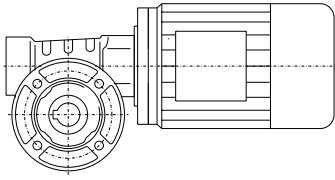
Mounting type	Order No. 14th position	Code in type designation (4th position)	
Foot-mounted design	A	C	
Housing flange (C-type)	H	Z	
Design with torque arm	D	D	
Flange-mounted design (A-type)	F	F	

Geared motors

Worm geared motors

Mounting types

Selection and ordering data (continued)

Worm gear unit with torque arm

The torque arm consists of an arm with an eye; it can be screwed onto the gear unit housing with an axis intersection of 45° in any one of five positions around the output.

If **D** appears in the **14th position** of the order number, the torque arm will be delivered loose.

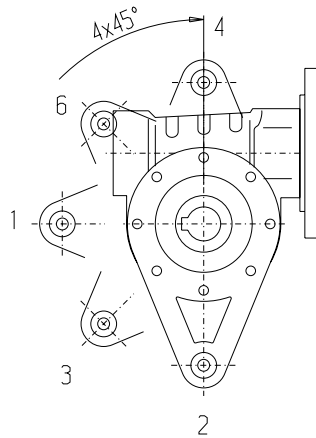

The shafts, mounting positions, and dimensions correspond to the design featuring a housing flange.

Position of feet

The feet can be mounted in three different positions.

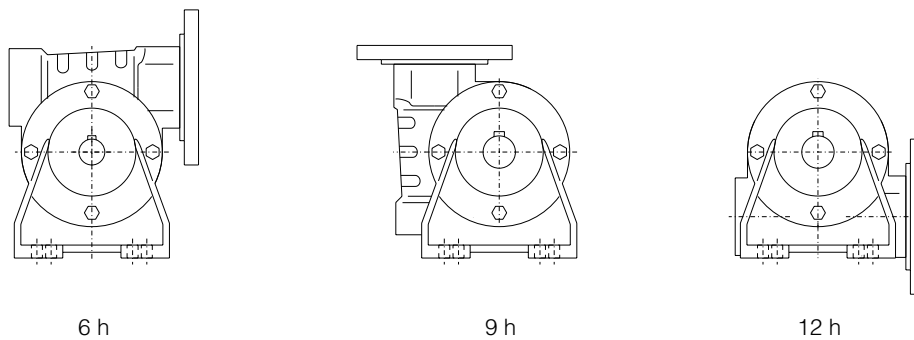

Order codes:

Foot position 6 h **H32**

Foot position 9 h **H33**

Foot position 12 h **H34**

Selection and ordering data

Shaft design	Order No. 8th position	Order No. suffix	Shaft dimensions		
Worm gear unit SC, foot-mounted design					
Size			SC.C36	SC.C50	SC.C63
Solid shaft with parallel key	1		V18 x 40	V25 x 50	V25 x 60
Hollow shaft	5		H18 x 76	H20 x 88	H25 x 120
	6		H20 x 76*	H25 x 88*	
Worm gear unit SC with housing flange/torque arm					
Size			SC.Z36 SC.D36	SC.Z50 SC.D50	SC.Z63 SC.D63
Solid shaft with parallel key	1		V18 x 40	V25 x 50	V25 x 60
Hollow shaft	5		H18 x 76	H20 x 88	H25 x 120
	6		H20 x 76*	H25 x 88*	
Worm gear unit SC, flange-mounted design (A-type)					
Size			SC.F36	SC.F50	SC.F63
Solid shaft with parallel key	1		V18 x 40	V25 x 50	V25 x 60
Hollow shaft	5		H18 x 76	H20 x 88	H25 x 120
	6		H20 x 76*	H25 x 88*	

^{*)} Preferred series

Geared motors

Worm geared motors

Flange-mounted designs (A-type)

Selection and ordering data

Order code	Flange diameter		
Worm gear unit SC			
Size	SC.F36	SC.F50	SC.F63
H02	103	116	180

The worm gear unit output flanges are available in two different lengths.

Design	Order code	Flange length		
		SC.F36	SC.F50	SC.F63
Short flange	G06	25	45	40
Long flange	G07	55	75	70

Selection and ordering data

The gear unit is lubricated for its entire service life in such a way that it can be installed and operated using all the mounting types / mounting positions listed below.

Please contact customer service to discuss the oil quantity if you wish to use a mounting position which is not shown here.

Position of the terminal box

The terminal box of the motor can be mounted in four different positions. See Chapter 8 for an accurate representation of the terminal box position and the corresponding order codes.

Worm gear unit SC, foot-mounted design, flange-mounted design, and with housing flange

Oil control valves:

These types are lubricated for life.

No breather, oil level, or drain plugs are present.

1 ... 4 Position of the terminal box, see Chapter 8

SCEC: B3-00 (IM B3-00)

Order code: Output side A **D06**, output side B **D08**

SCEF: B5-01 (IM B5-01)

Order code: Output side A **D22**, output side B **D24**

SCAD, SCAF, SCAZ: H-01

Order code: Output side A **D76**, output side B **D77**

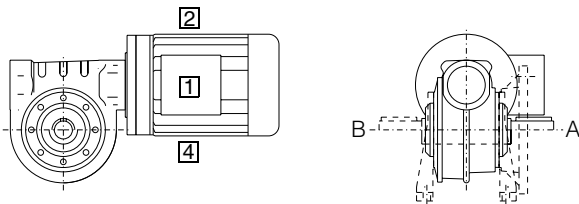

SCEC: B8-00 (IM B8-00)

Order code: Output side A **D68**, output side B **D70**

SCEF: B5-03 (IM B5-03)

Order code: Output side A **D32**, output side B **D34**

SCAD, SCAF, SCAZ: H-02

Order code: Output side A **D78**, output side B **D79**

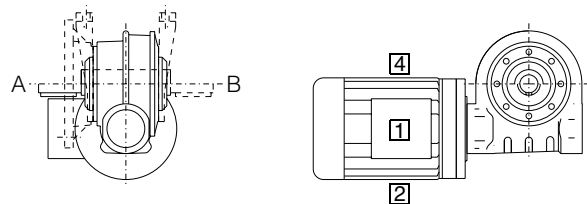

SCEC: B6-00 (IM B6-00)

Order code: Output side A **D38**, output side B **D40**

SCEF: B5-000 (IM B5-00)

Order code: Output side A **D18**, output side B **D20**

SCAD, SCAF, SCAZ: H-04

Order code: Output side A **D82**, output side B **D83**

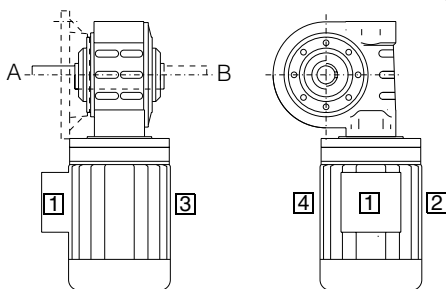

SCEC: B7-00 (IM B7-00)

Order code: Output side A **D59**, output side B **D61**

SCEF: B5-02 (IM B5-02)

Order code: Output side A **D27**, output side B **D29**

SCAD, SCAF, SCAZ: H-03

Order code: Output side A **D80**, output side B **D81**

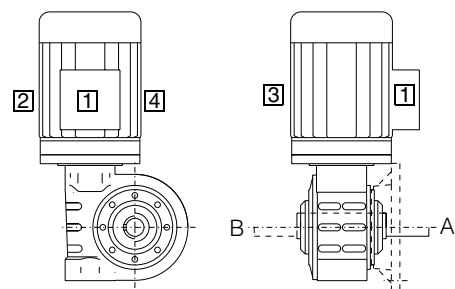

SCEC: V5-00 (IM V5-00)

Order code: Output side A **E03**, output side B **E05**

SCEF: V1-00 (IM V1-00)

Order code: Output side A **D90**, output side B **D92**

SCAD, SCAF, SCAZ: H-05

Order code: Output side A **D84**, output side B **D85**

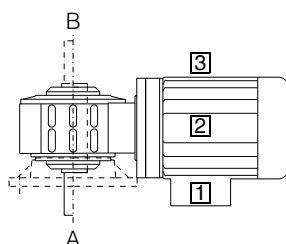

SCEC: V6-00 (IM V6-00)

Order code: Output side A **E15**, output side B **E17**

SCEF: V3-00 (IM V3-00)

Order code: Output side A **D98**, output side B **E00**

SCAD, SCAF, SCAZ: H-06

Order code: Output side A **D86**, output side B **D87**

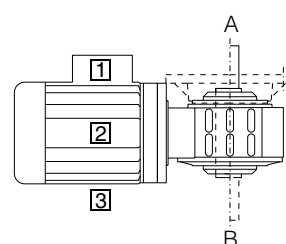

Geared motors

Worm geared motors

Special versions

Worm gear unit SC for attaching IEC motors (solo gear unit)

Worm gear units can also be supplied as solo gear units to enable third-party motors to be attached.

Two flange sizes are available on the input side.

During configuration, enter **A** in the **10th position** of the order number and **0** in the **11th to 13th positions**.

Order codes:

Flange B5 **N19**

Flange B14 **N21**

Gear unit type	Motor IM-B14	Motor IM-B5	Flange diameter
SC36-K4	63	–	120
	71	63	140
SC50-K4	63	–	120
	71	63	140
	80/90	71	160
	–	80	200
SC63-K4	71	–	140
	80/90	71	160
	–	80/90	200

6

Second output shaft extension

If required, worm gear units with a solid shaft are available with a second shaft extension.

See the dimension drawings for the corresponding design for the relevant dimensions.

Order code **G73**

Dimension drawing overview

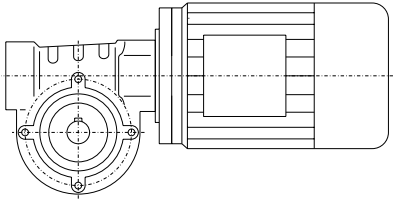
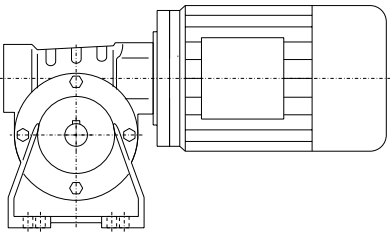
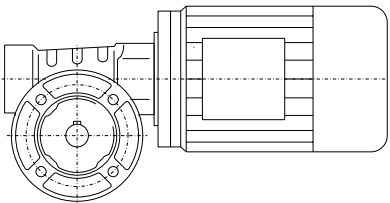
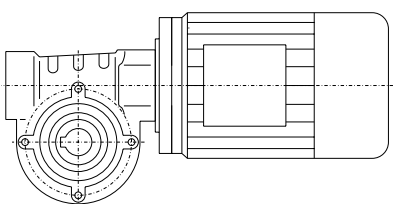
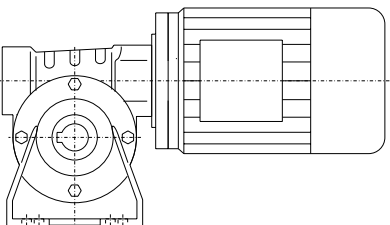
	Gear unit type	Dimension drawing on page
	SCEZ36	6/19
	SCEZ50	6/26
	SCEZ63	6/33
	SCEC36	6/20
	SCEC50	6/27
	SCEC63	6/34
	SCEF36	6/21
	SCEF50	6/28
	SCEF63	6/35
	SCAZ36	6/22
	SCAZ50	6/29
	SCAZ63	6/36
	SCAC36	6/23
	SCAC50	6/30
	SCAC63	6/37

Geared motors

Worm geared motors

Dimensions

Dimension drawing overview (continued)

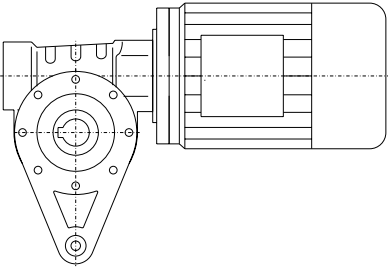
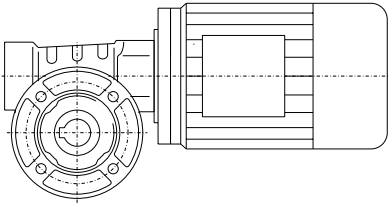
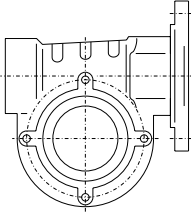
	Gear unit type	Dimension drawing on page
	SCAD36	6/24
	SCAD50	6/31
	SCAD63	6/38
	SCAF36	6/25
	SCAF50	6/32
	SCAF63	6/39
	SC.36-K4 ... SC.63-K4	6/40

Gear unit SCEZ36, housing-flange-mounted design

SCEZ012

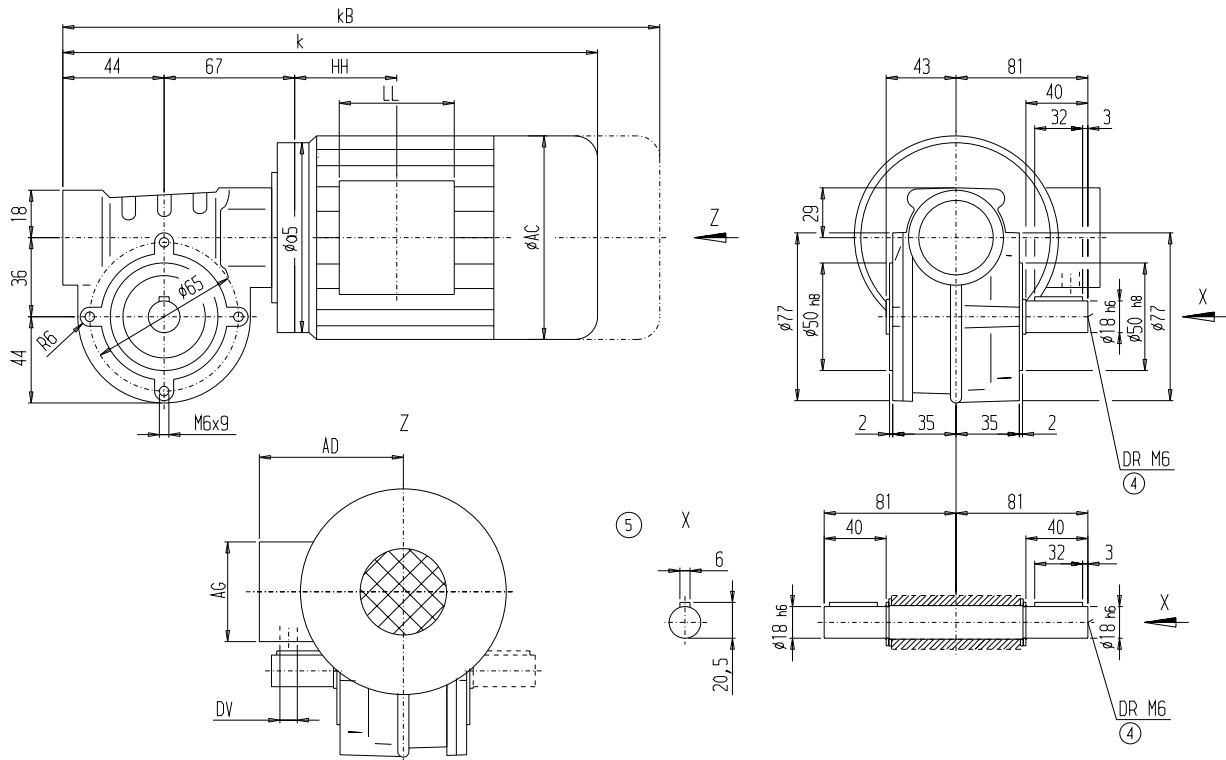

Motor	SCEZ36										Weight SCEZ36
	k	kB	AC	AD	AG	LL	HH	a5	DV		
								IM-B14	IM-B5		
LA71	318.5	373.5	139	146	90	90	71.5	140	-	M20x1.5/M25x2.5	8
LA71Z	337.5	392.5	139	146	90	90	71.5	140	-	M20x1.5/M25x2.5	8

④ DIN 332

⑤ Parallel key/keyway DIN 6885

Geared motors

Worm geared motors

Dimensions

Gear unit SCEC36, foot-mounted design "6 h"

SCEC012

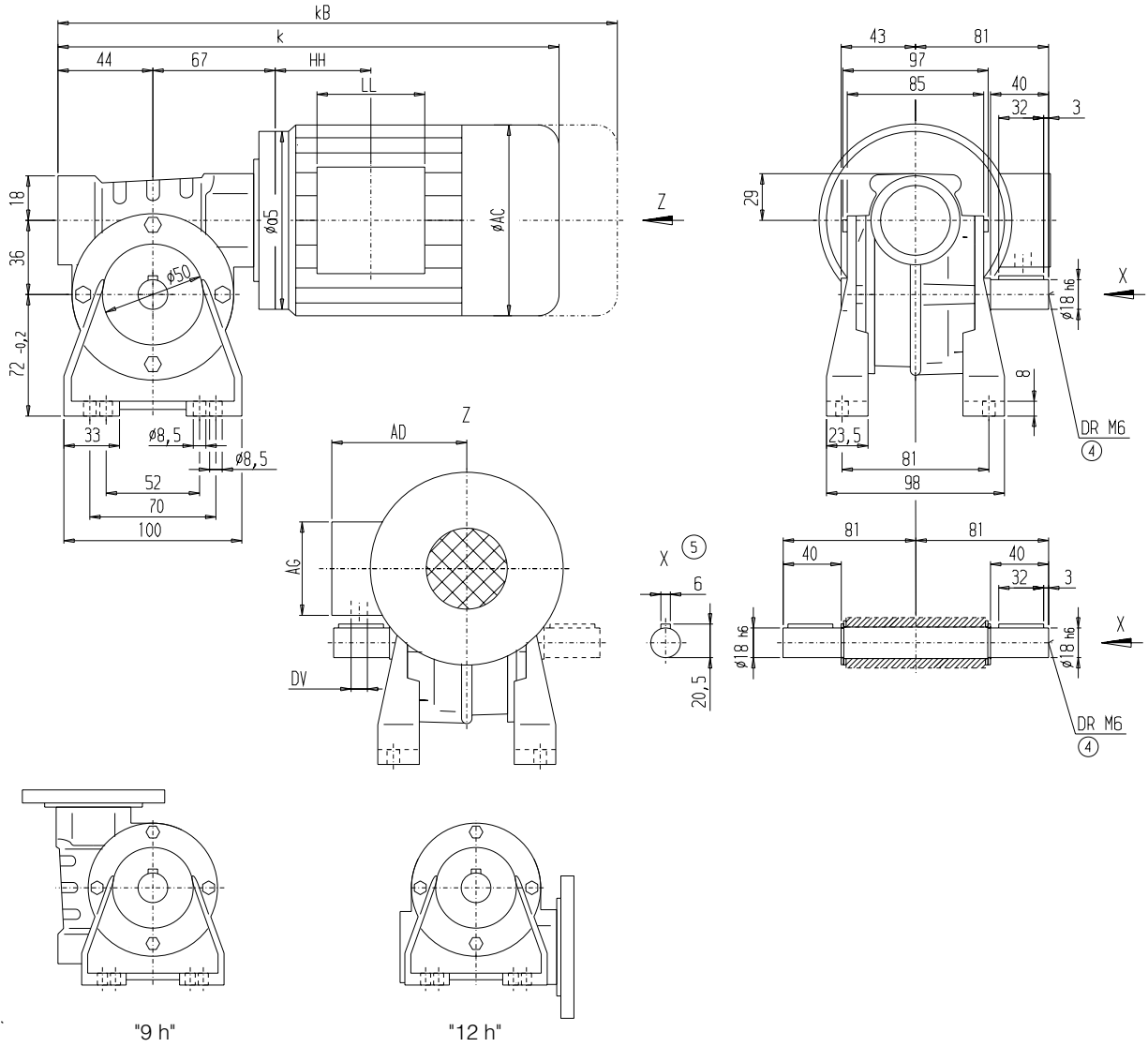

6

Motor	SCEC36		AC	AD	AG	LL	HH	a5	IM		DV	Weight SCEC36
	k	kB							B14	B5		
LA71	318.5	373.5	139	146	90	90	71.5	140	-	M20x1.5/M25x2.5	8	
LA71Z	337.5	392.5	139	146	90	90	71.5	140	-	M20x1.5/M25x2.5	8	

© DIN 332

© Parallel key / keyway DIN 6885

Gear unit SCEF36, flange-mounted design

SCEF012

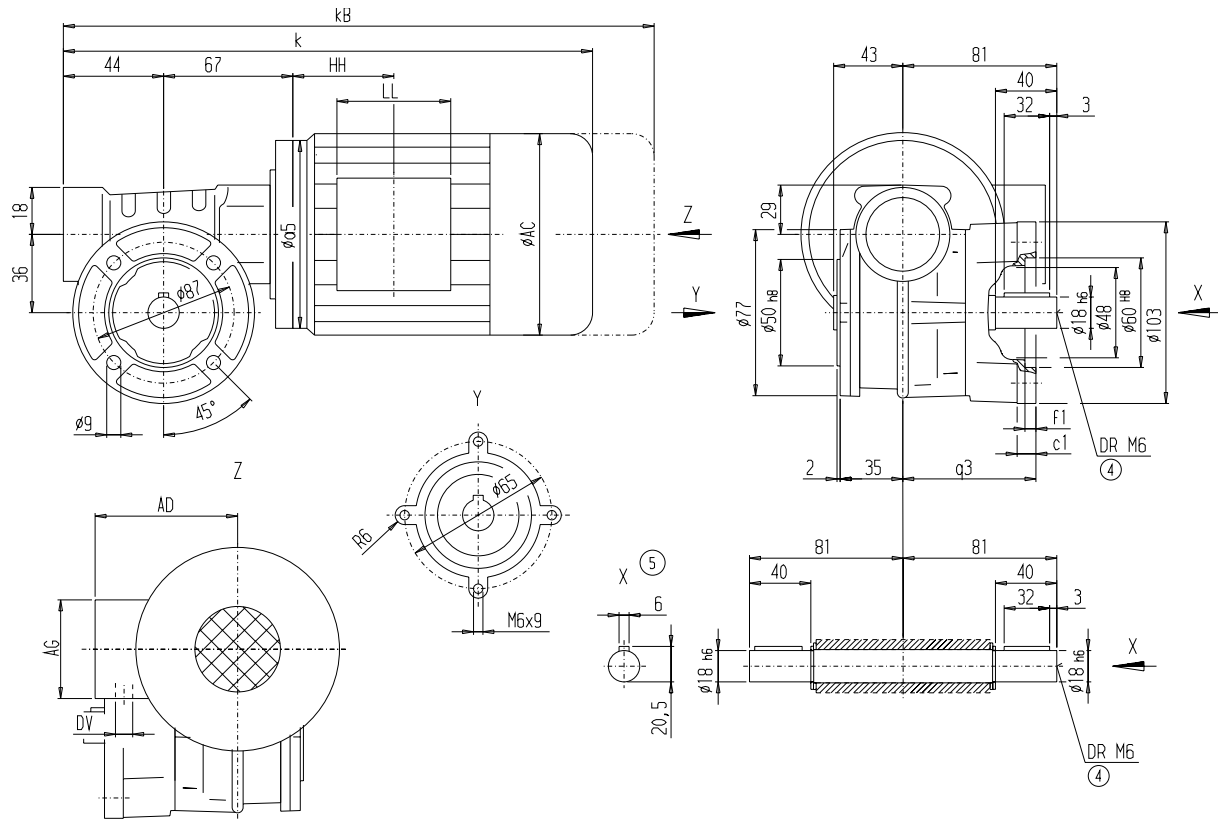

Flange	q3	c1	f1
Short	60	9	5
Long	90	9	5

Motor	SCEF36		AC	AD	AG	LL	HH	a5		DV	Weight SCEF36
	k	kB						IM-B14	IM-B5		
LA71	318.5	373.5	139	146	90	90	71.5	140	–	M20x1.5/M25x2.5	8
LA71Z	337.5	392.5	139	146	90	90	71.5	140	–	M20x1.5/M25x2.5	8

© DIN 332

© Parallel key / keyway DIN 6885

Geared motors

Worm geared motors

Dimensions

Gear unit SCAZ36, shaft-mounted design with housing flange

SCAZ012

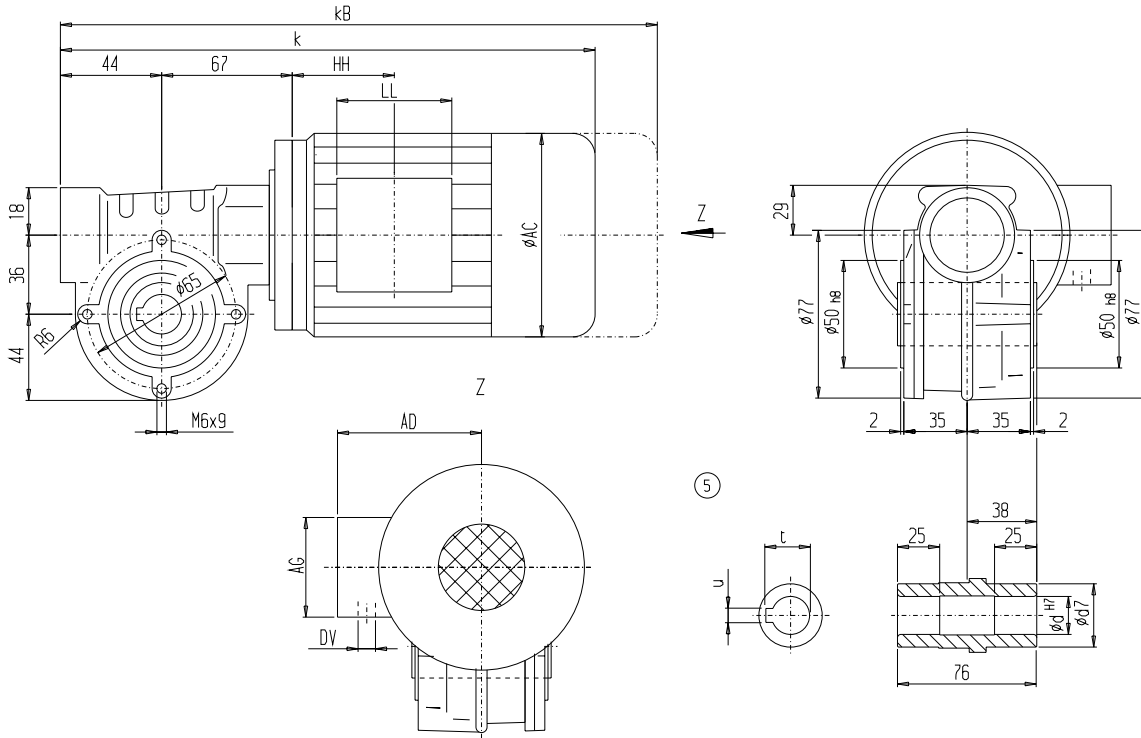

d	d7	u	t
18	30	6	20.8
20*	30	6	22.8

*) Preferred series

Motor	SCAZ36		AC	AD	AG	LL	HH	a5		DV	Weight SCAZ36
	k	kB						IM-B14	IM-B5		
LA71	318.5	373.5	139	146	90	90	71.5	140	–	M20x1.5/M25x2.5	8
LA71Z	337.5	392.5	139	146	90	90	71.5	140	–	M20x1.5/M25x2.5	8

④ DIN 332

© Parallel key / keyway DIN 6885

Gear unit SCAC36, shaft-mounted design, foot-mounted design "6 h"

SCAC012

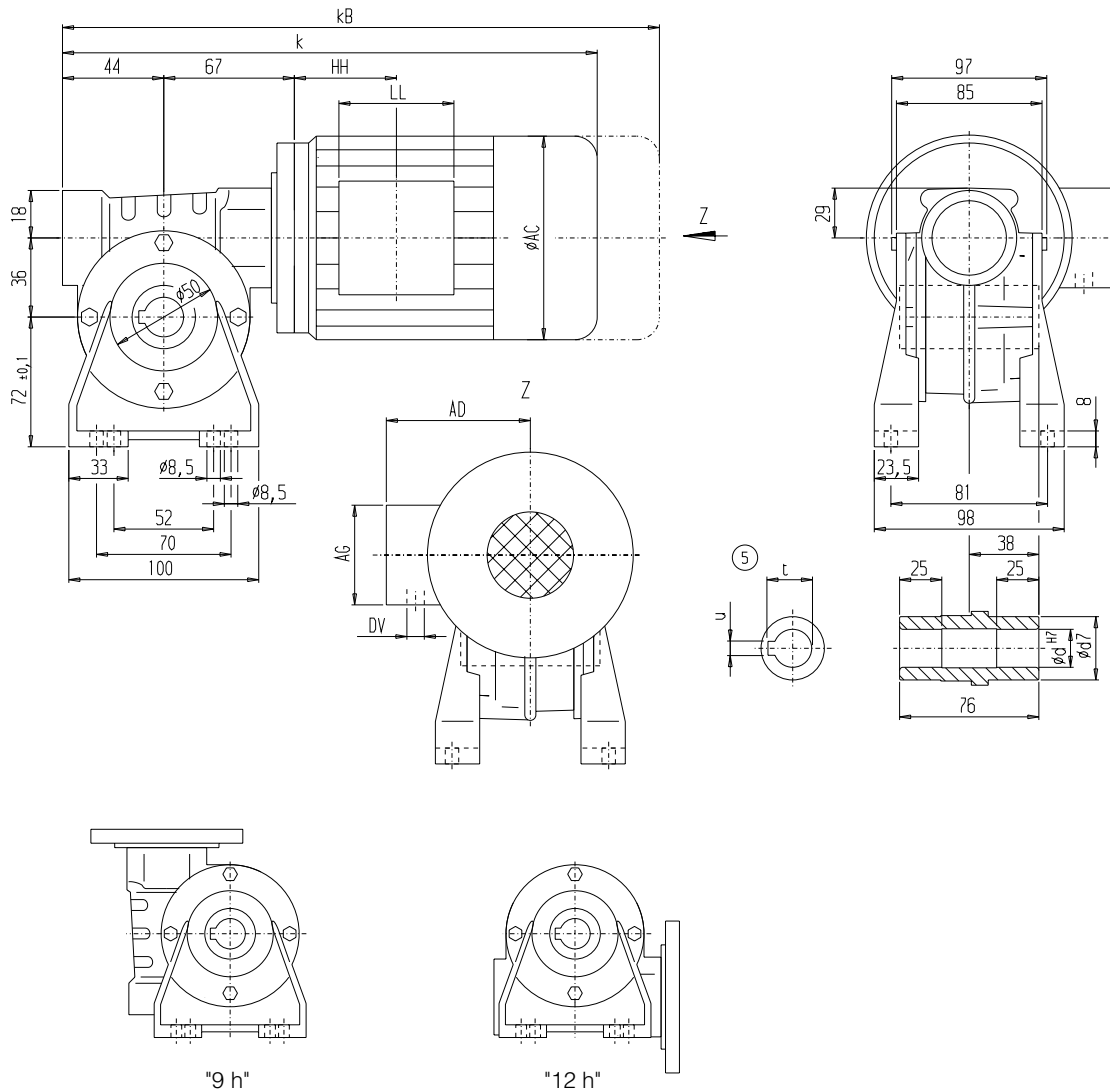

d	d7	u	t
18	30	6	20.8
20*	30	6	22.8

*) Preferred series

Motor	SCAC36									Weight SCAC36	
	k	kB	AC	AD	AG	LL	HH	a5	DV		
LA71	318.5	373.5	139	146	90	90	71.5	140	–	M20x1.5/M25x2.5	8
LA71Z	337.5	392.5	139	146	90	90	71.5	140	–	M20x1.5/M25x2.5	8

④ DIN 332

© Parallel key / keyway DIN 6885

Geared motors

Worm geared motors

Dimensions

Gear unit SCAD36, shaft-mounted design with torque arm

SCAD012

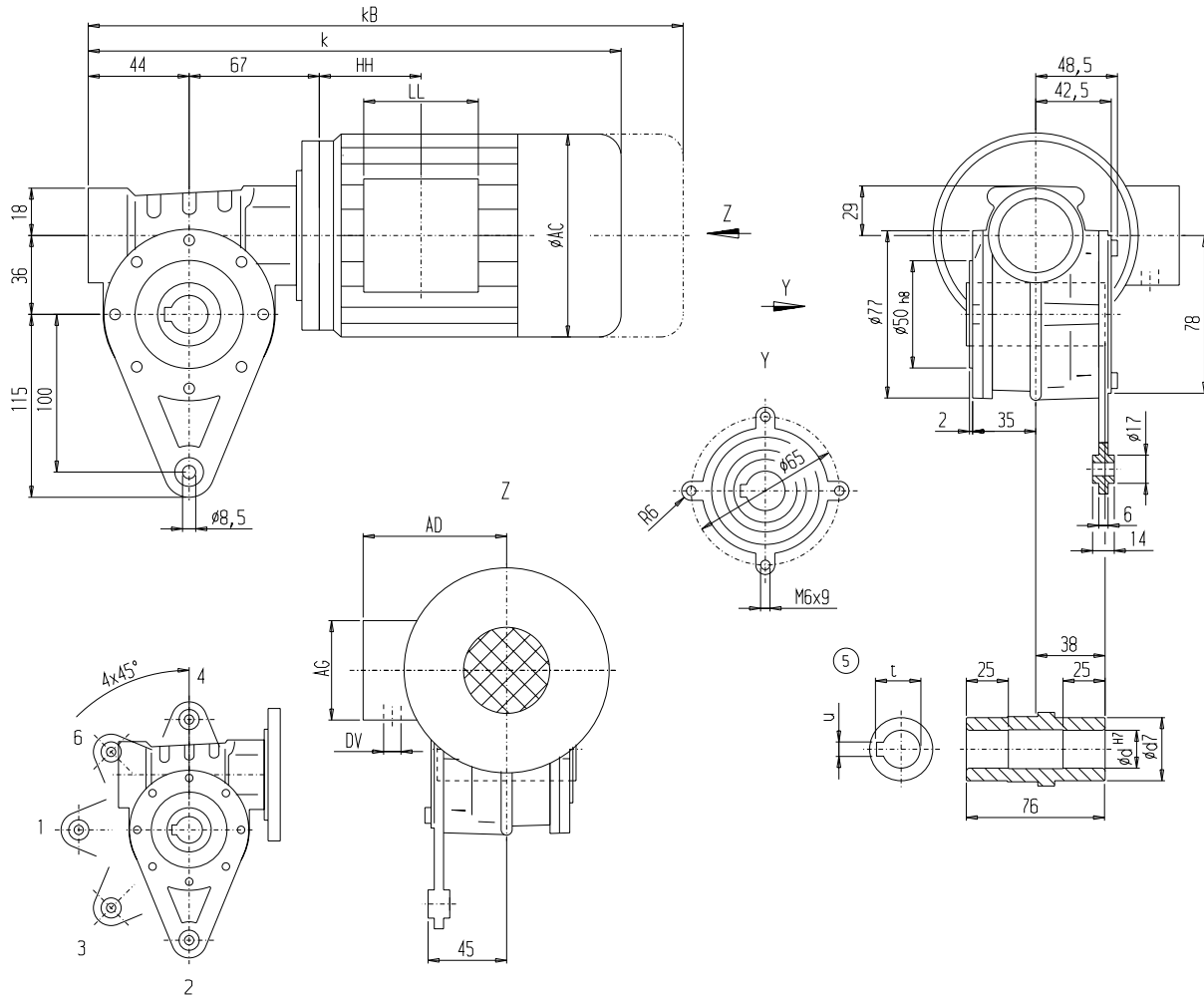

d	d7	u	t
18	30	6	20.8
20*	30	6	22.8

*) Preferred series

Motor	SCAD36								Weight	
	k	kB	AC	AD	AG	LL	HH	a5	DV	SCAD36
LA71	318.5	373.5	139	146	90	90	71.5	IM-B14 140	IM-B5 -	M20x1.5/M25x2.5 8
LA71Z	337.5	392.5	139	146	90	90	71.5	140	-	M20x1.5/M25x2.5 8

④ DIN 332

© Parallel key / keyway DIN 6885

Gear unit SCAF36, shaft-mounted design with flange

SCAF012

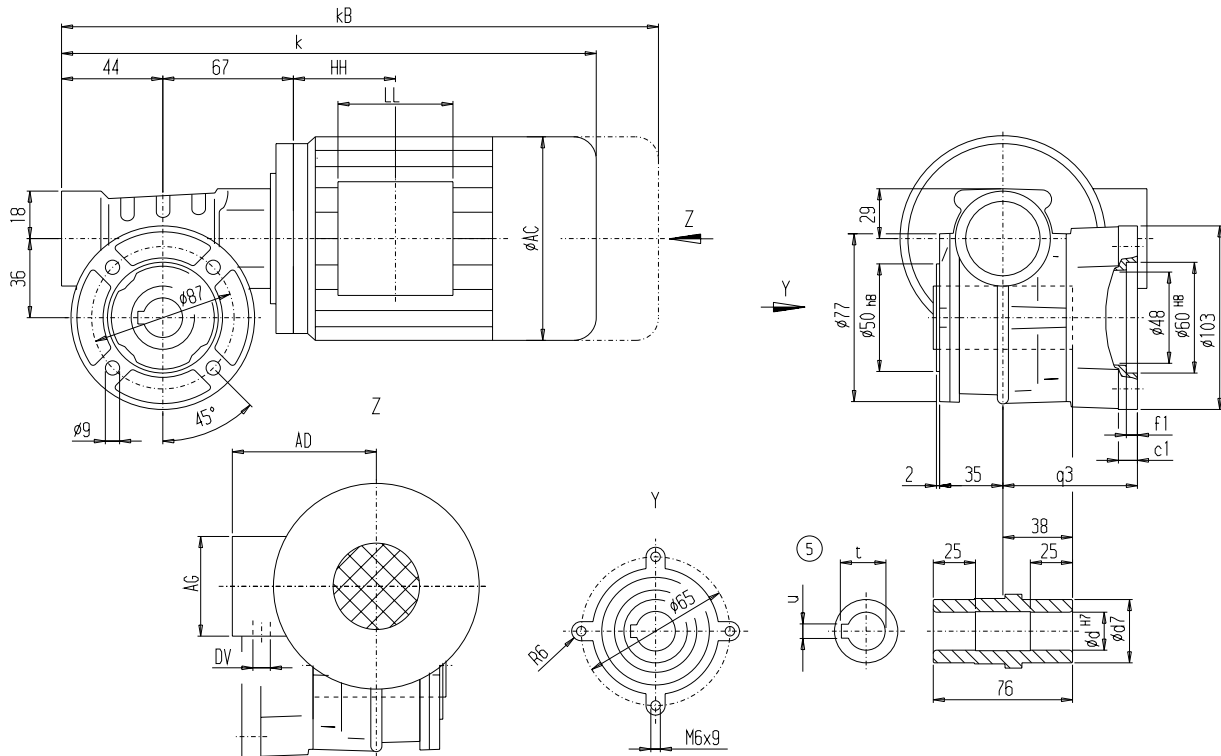

Flange	q3	c1	f1
Short	60	9	5
Long	90	9	5

d	d7	u	t
18	30	6	20.8
20*	30	6	22.8

*) Preferred series

Motor	SCAF36								IM-B14	IM-B5	DV	Weight SCAF36
	k	kB	AC	AD	AG	LL	HH	a5				
LA71	318.5	373.5	139	146	90	90	71.5	140	–	M20x1.5/M25x2.5	8	
LA71Z	337.5	392.5	139	146	90	90	71.5	140	–	M20x1.5/M25x2.5	8	

© DIN 332

© Parallel key / keyway DIN 6885

Geared motors

Worm geared motors

Dimensions

Gear unit SCEZ50, housing-flange-mounted design

SCEZ012

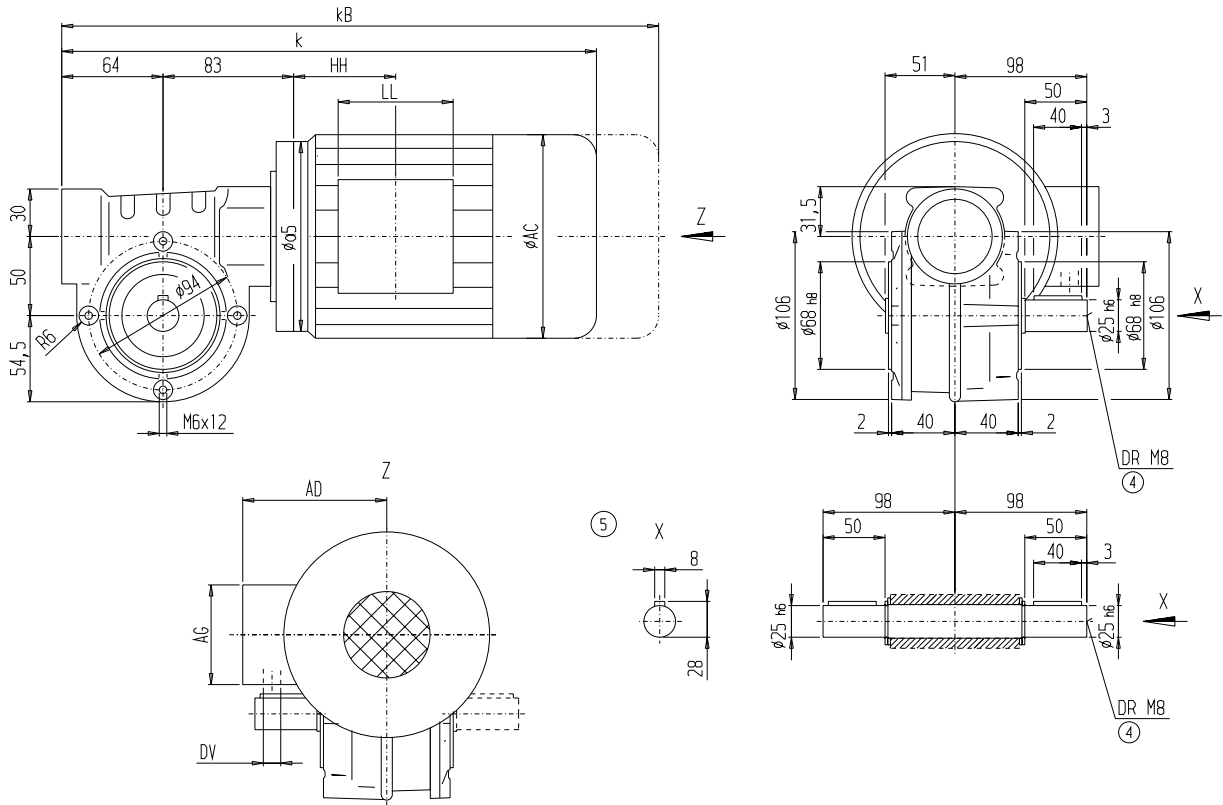

6

Motor	SCEZ50										Weight SCEZ50	
	k	kB	AC	AD	AG	LL	HH	a5	IM-B14	IM-B5		DV
LA71	355.0	410	139.0	146	90	90	71.5	140	160	160	M20x1.5/M25x2.5	10
LA71Z	374.0	429	139.0	146	90	90	71.5	140	160	160	M20x1.5/M25x2.5	10
LA80	392.5	456	156.5	155	90	90	71.0	160	200	200	M20x1.5/M25x2.5	15

© DIN 332

© Parallel key / keyway DIN 6885

Gear unit SCEC50, foot-mounted design "6 h"

SCEC012

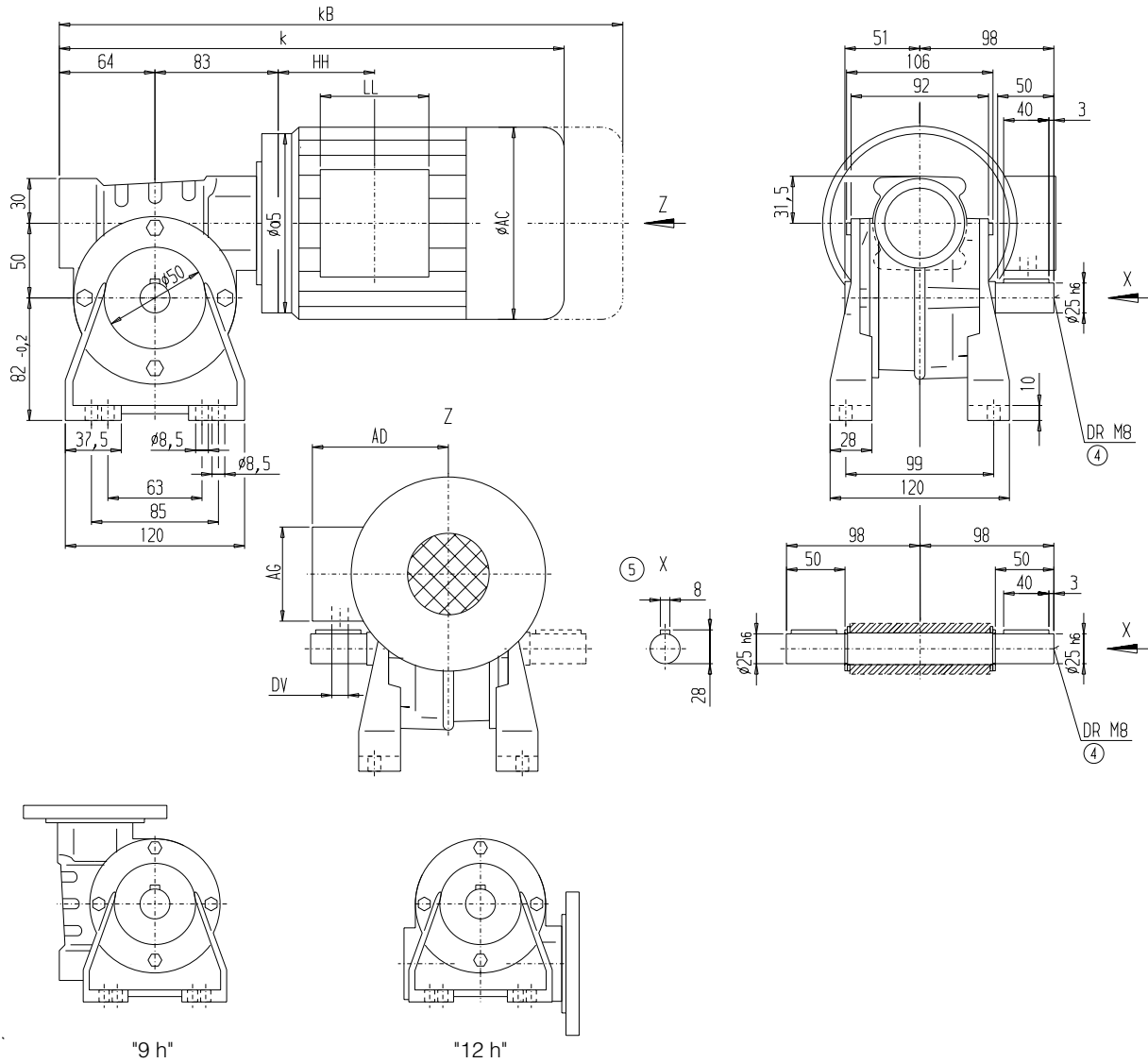

Motor	SCEC50		AC	AD	AG	LL	HH	a5		DV	Weight SCEC50
	k	kB						IM-B14	IM-B5		
LA71	355.0	410	139.0	146	90	90	71.5	140	160	M20x1.5/M25x2.5	10
LA71Z	374.0	429	139.0	146	90	90	71.5	140	160	M20x1.5/M25x2.5	10
LA80	392.5	456	156.5	155	90	90	71.0	160	200	M20x1.5/M25x2.5	15

Geared motors

Worm geared motors

Dimensions

Gear unit SCEF50, flange-mounted design

SCEF012

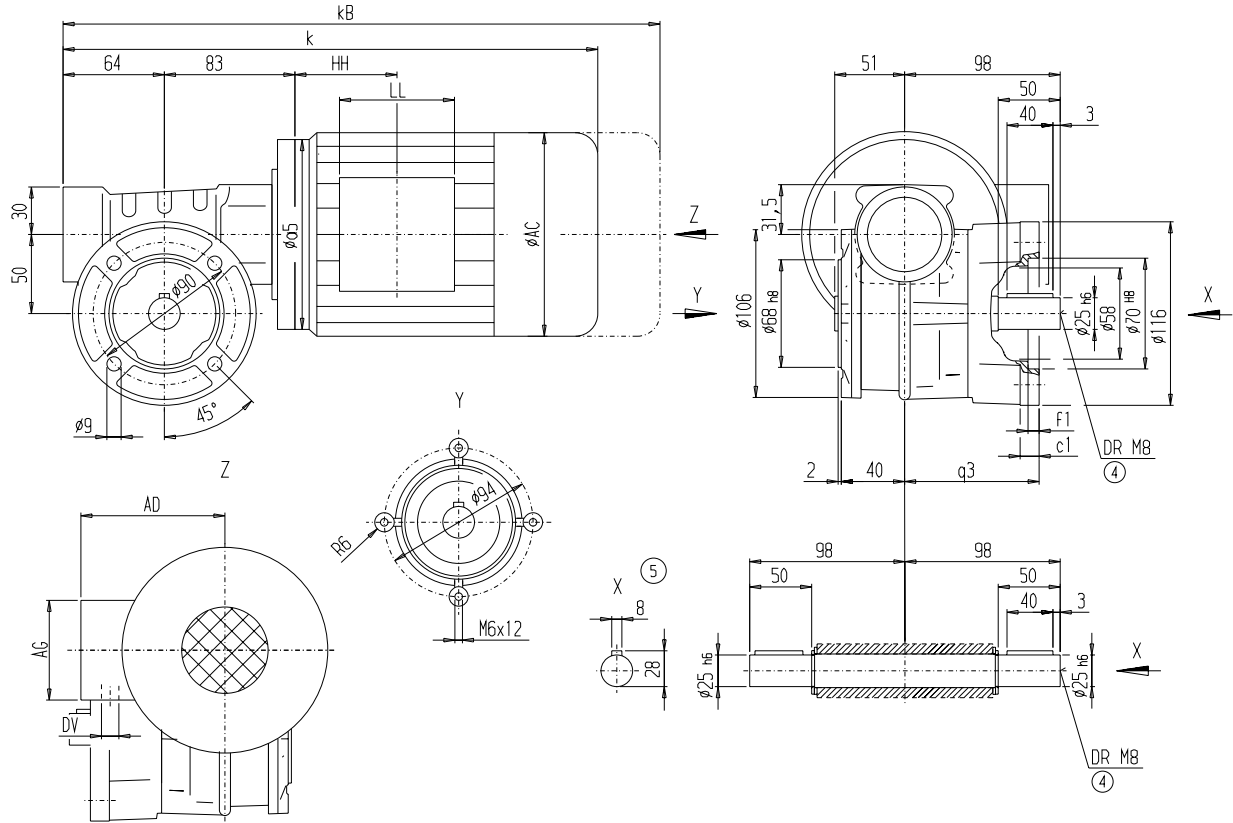

Flange	q3	c1	f1
Short	85	12	7
Long	115	12	7

Motor	SCEF50		AC	AD	AG	LL	HH	a5		DV	Weight SCEF50
	k	kB						IM-B14	IM-B5		
LA71	355.0	410	139.0	146	90	90	71.5	140	160	M20x1.5/M25x2.5	10
LA71Z	374.0	429	139.0	146	90	90	71.5	140	160	M20x1.5/M25x2.5	10
LA80	392.5	456	156.5	155	90	90	71.0	160	200	M20x1.5/M25x2.5	15

④ DIN 332

⑤ Parallel key / keyway DIN 6885

Gear unit SCAZ50, shaft-mounted design with housing flange

SCAZ012

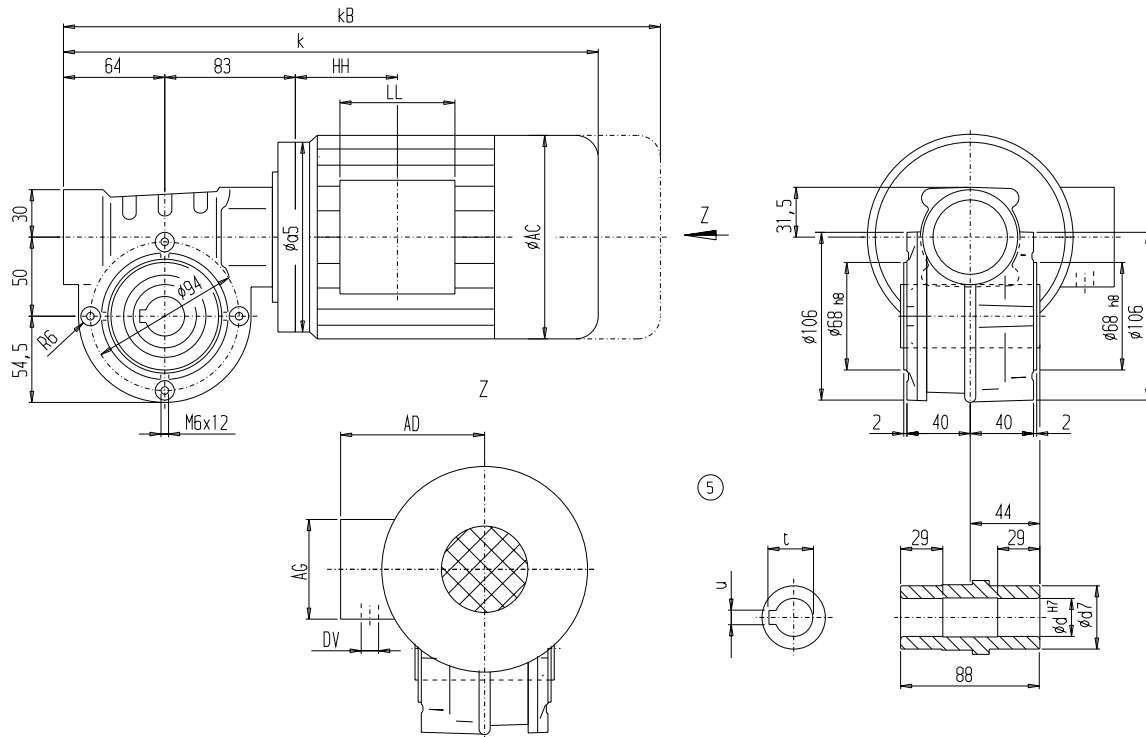

d	d7	u	t
20	40	6	22.8
25*	40	8	28.3

*) Preferred series

Motor	SCAZ50								DV	Weight SCAZ50	
	k	kB	AC	AD	AG	LL	HH	a5			
LA71	355.0	410	139.0	146	90	90	71.5	140	160	M20x1.5/M25x2.5	9
LA71Z	374.0	429	139.0	146	90	90	71.5	140	160	M20x1.5/M25x2.5	9
LA80	392.5	456	156.5	155	90	90	71.0	160	200	M20x1.5/M25x2.5	14

© DIN 332

© Parallel key / keyway DIN 6885

Geared motors

Worm geared motors

Dimensions

Gear unit SCAC50, shaft-mounted design, foot-mounted design "6 h"

SCAC012

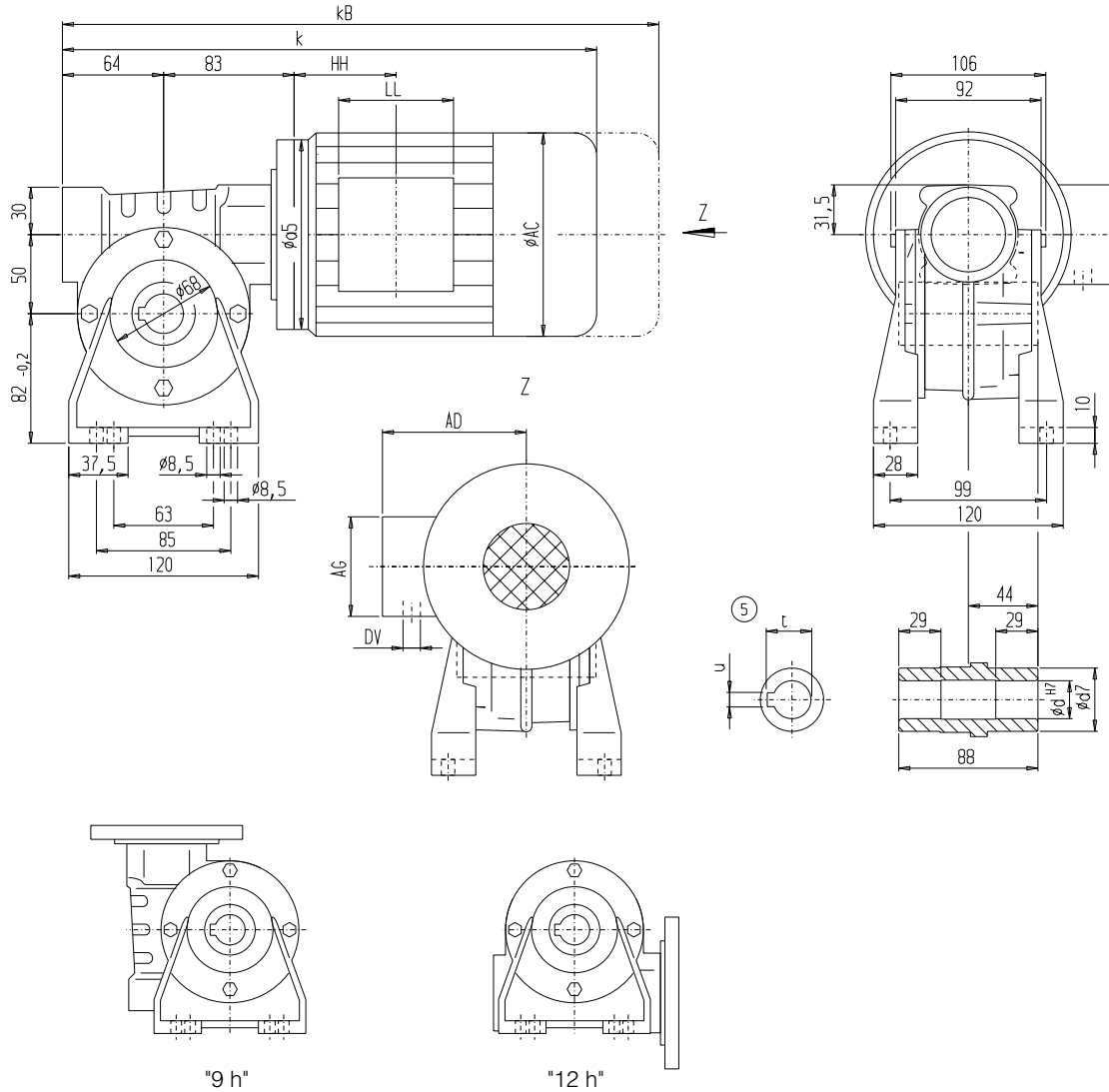

d	d7	u	t
20	40	6	22.8
25*	40	8	28.3

*) Preferred series

Motor	SCAC50								Weight		
	k	kB	AC	AD	AG	LL	HH	a5	DV	SCAC50	
LA71	355.0	410	139.0	146	90	90	71.5	IM-B14 140	IM-B5 160	M20x1.5/M25x2.5	9
LA71Z	374.0	429	139.0	146	90	90	71.5	140	160	M20x1.5/M25x2.5	9
LA80	392.5	456	156.5	155	90	90	71.0	160	200	M20x1.5/M25x2.5	14

© DIN 332

© Parallel key / keyway DIN 6885

Gear unit SCAD50, shaft-mounted design with torque arm

SCAD012

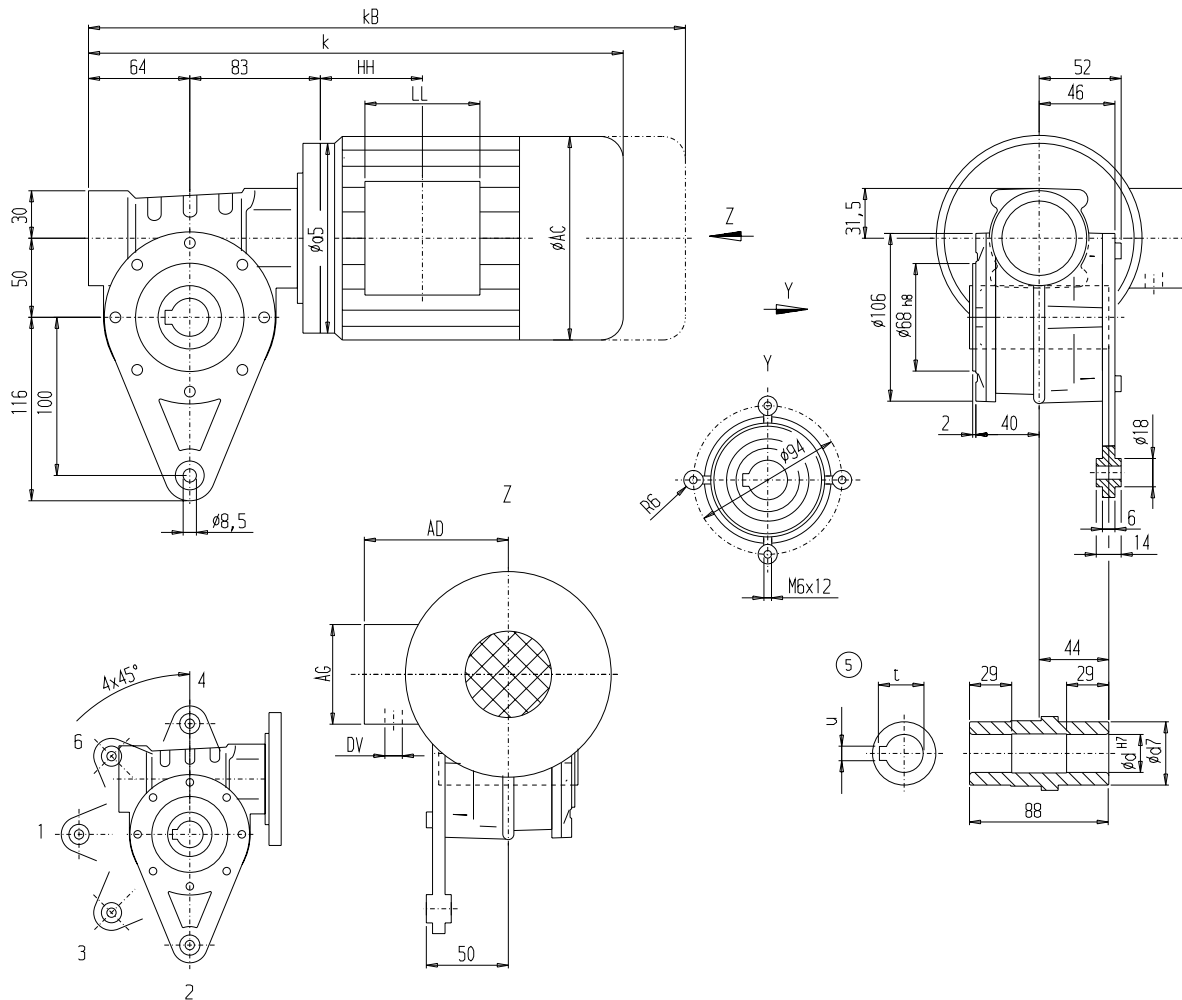

d	d7	u	t
20	40	6	22.8
25*	40	8	28.3

*) Preferred series

Motor	SCAD50								Weight	
	k	kB	AC	AD	AG	LL	HH	a5	DV	SCAD50
LA71	355.0	410	139.0	146	90	90	71.5	IM-B14 140	IM-B5 160	M20x1.5/M25x2.5 9
LA71Z	374.0	429	139.0	146	90	90	71.5	140	160	M20x1.5/M25x2.5 9
LA80	392.5	456	156.5	155	90	90	71.0	160	200	M20x1.5/M25x2.5 14

Geared motors

Worm geared motors

Dimensions

Gear unit SCAF50, shaft-mounted design with flange

SCAF012

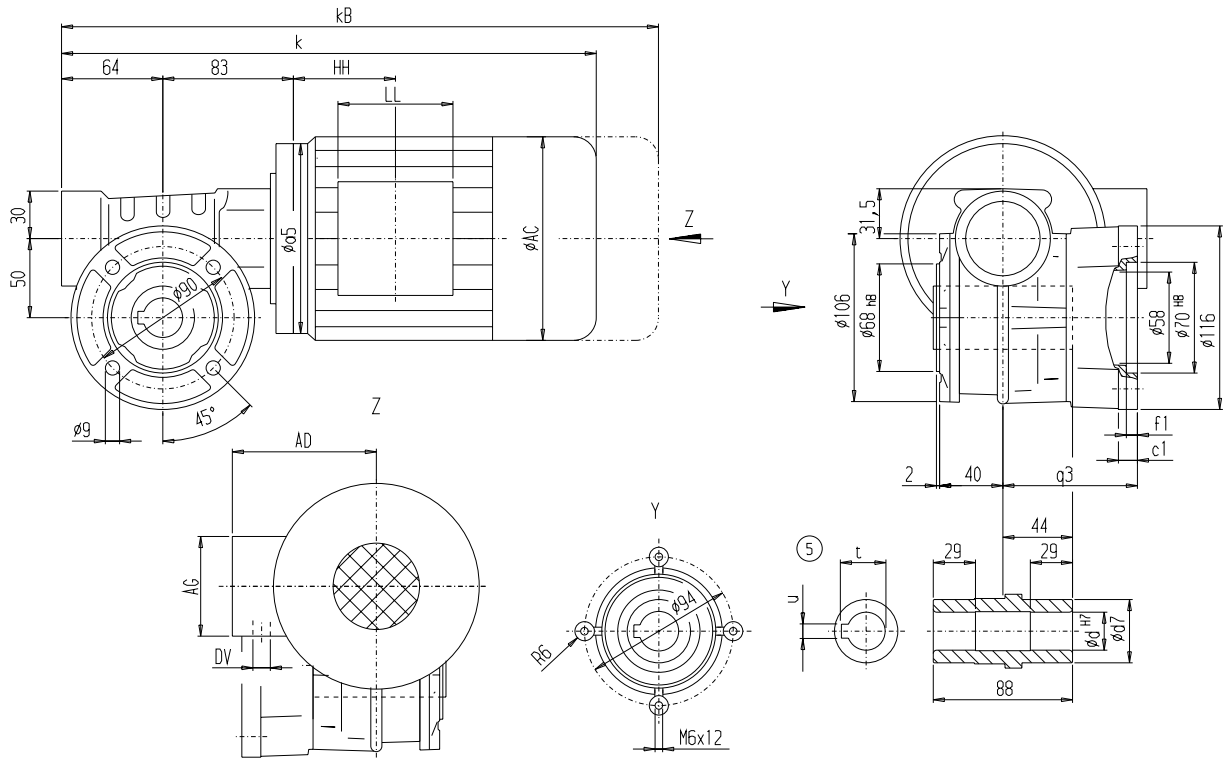

Flange	q3	c1	f1
Short	85	12	7
Long	115	12	7

d	d7	u	t
20	40	6	22.8
25*	40	8	28.3

*) Preferred series

Motor	SCAF50								IM-B14		IM-B5	DV	Weight SCAF50
	k	kB	AC	AD	AG	LL	HH	a5					
LA71	355.0	410	139.0	146	90	90	71.5	140	160	M20x1.5/M25x2.5	9		
LA71Z	374.0	429	139.0	146	90	90	71.5	140	160	M20x1.5/M25x2.5	9		
LA80	392.5	456	156.5	155	90	90	71.0	160	200	M20x1.5/M25x2.5	14		

⊗ DIN 332

⊗ Parallel key / keyway DIN 6885

Gear unit SCEZ63, housing-flange-mounted design

SCEZ012

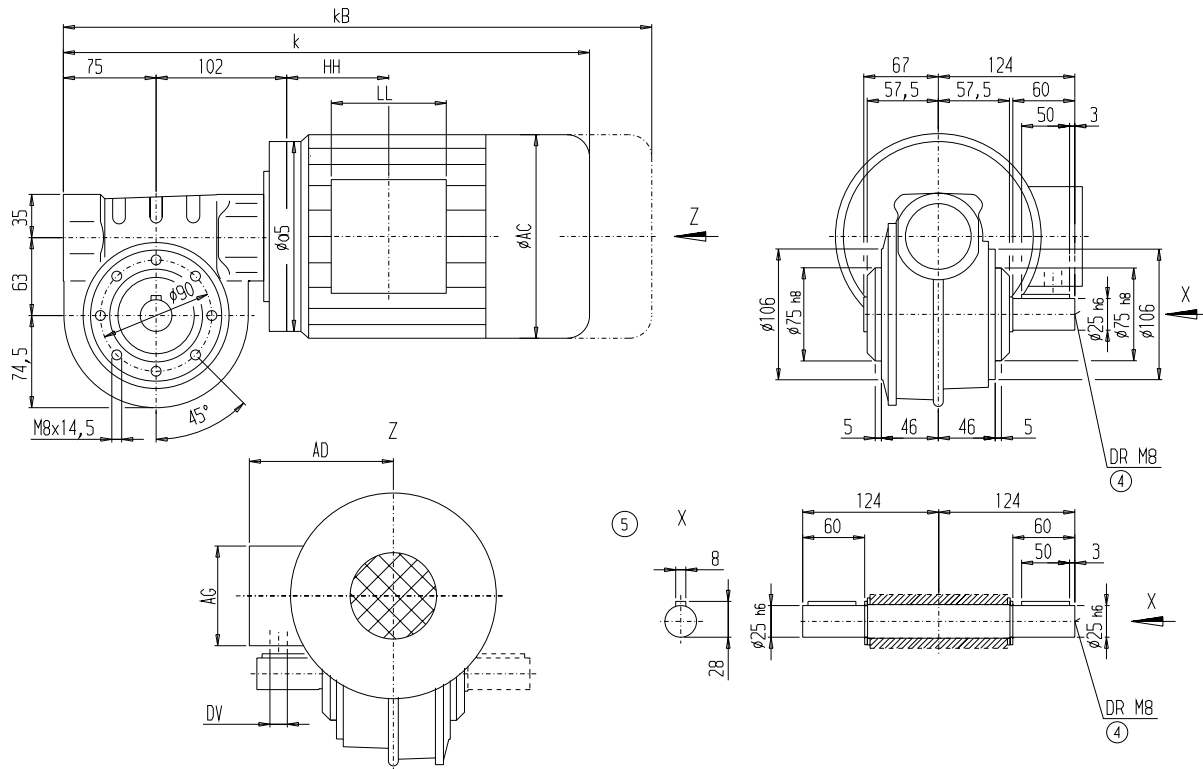

Motor	SCEZ63		AC	AD	AG	LL	HH	a5		DV	Weight SCEZ63
	k	kB						IM-B14	IM-B5		
LA71	385.0	440	139.0	146	90	90	71.5	140	160	M20x1.5/M25x2.5	13
LA71Z	404.0	459	139.0	146	90	90	71.5	140	160	M20x1.5/M25x2.5	13
LA80	422.5	486	156.5	155	90	90	71.0	160	200	M20x1.5/M25x2.5	18
LA90S	469.0	540	174.0	163	90	90	86.5	160	200	M20x1.5/M25x2.5	22
LA90L	469.0	540	174.0	163	90	90	101.0	160	200	M20x1.5/M25x2.5	22
LA90ZL	514.0	585	174.0	163	90	90	101.0	160	200	M20x1.5/M25x2.5	25

④ DIN 332

⑤ Parallel key / keyway DIN 6885

Geared motors

Worm geared motors

Dimensions

Gear unit SCEC63, foot-mounted design "6 h"

SCEC012

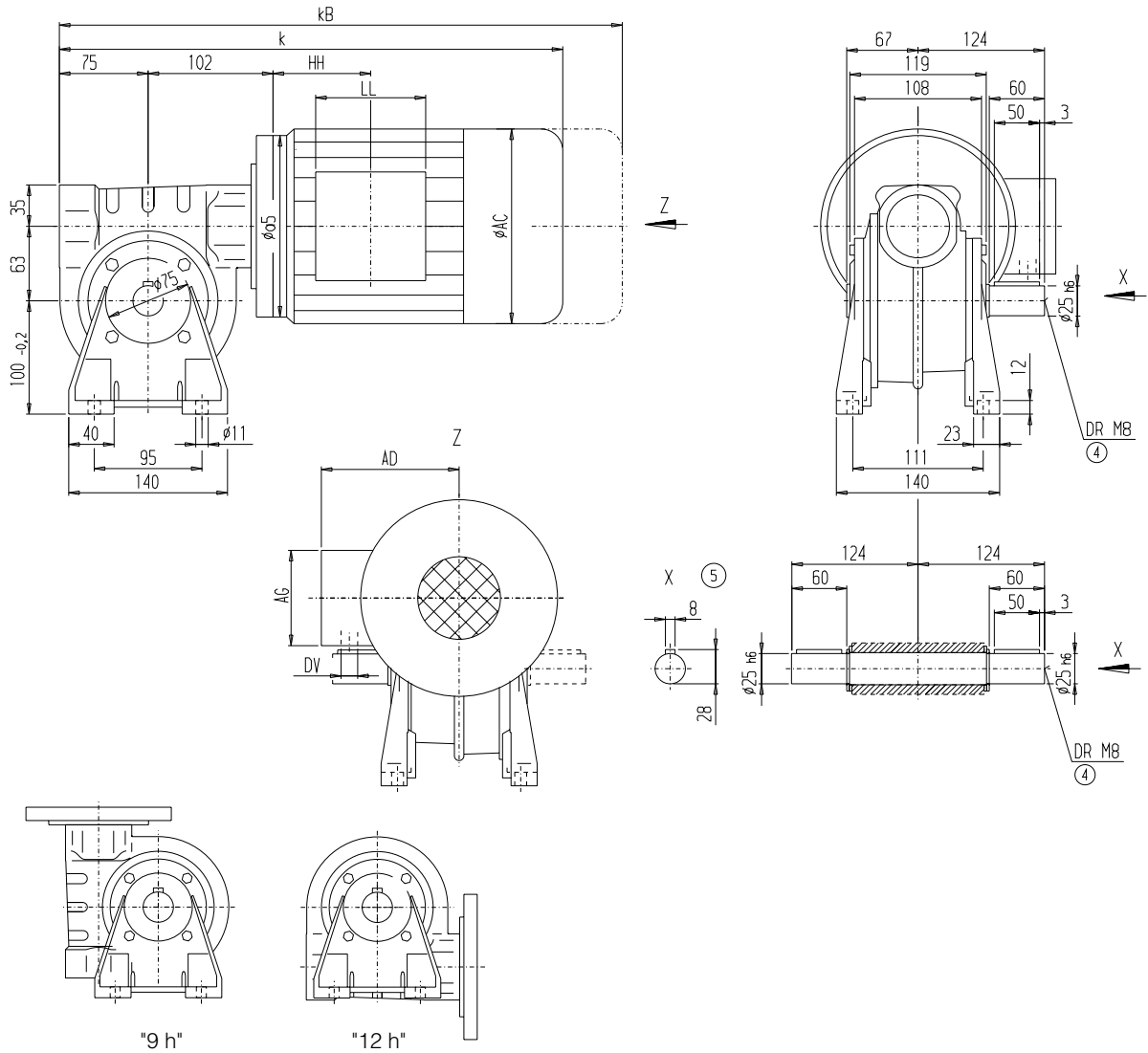

6

Motor	SCEC63		AC	AD	AG	LL	HH	a5		DV	Weight SCEC63
	k	kB						IM-B14	IM-B5		
LA71	385.0	440	139.0	146	90	90	71.5	140	160	M20x1.5/M25x2.5	14
LA71Z	404.0	459	139.0	146	90	90	71.5	140	160	M20x1.5/M25x2.5	14
LA80	422.5	486	156.5	155	90	90	71.0	160	200	M20x1.5/M25x2.5	19
LA90S	469.0	540	174.0	163	90	90	86.5	160	200	M20x1.5/M25x2.5	23
LA90L	469.0	540	174.0	163	90	90	101.0	160	200	M20x1.5/M25x2.5	23
LA90ZL	514.0	585	174.0	163	90	90	101.0	160	200	M20x1.5/M25x2.5	26

Ⓒ DIN 332

Ⓒ Parallel key / keyway DIN 6885

Gear unit SCEF63, flange-mounted design

SCEF012

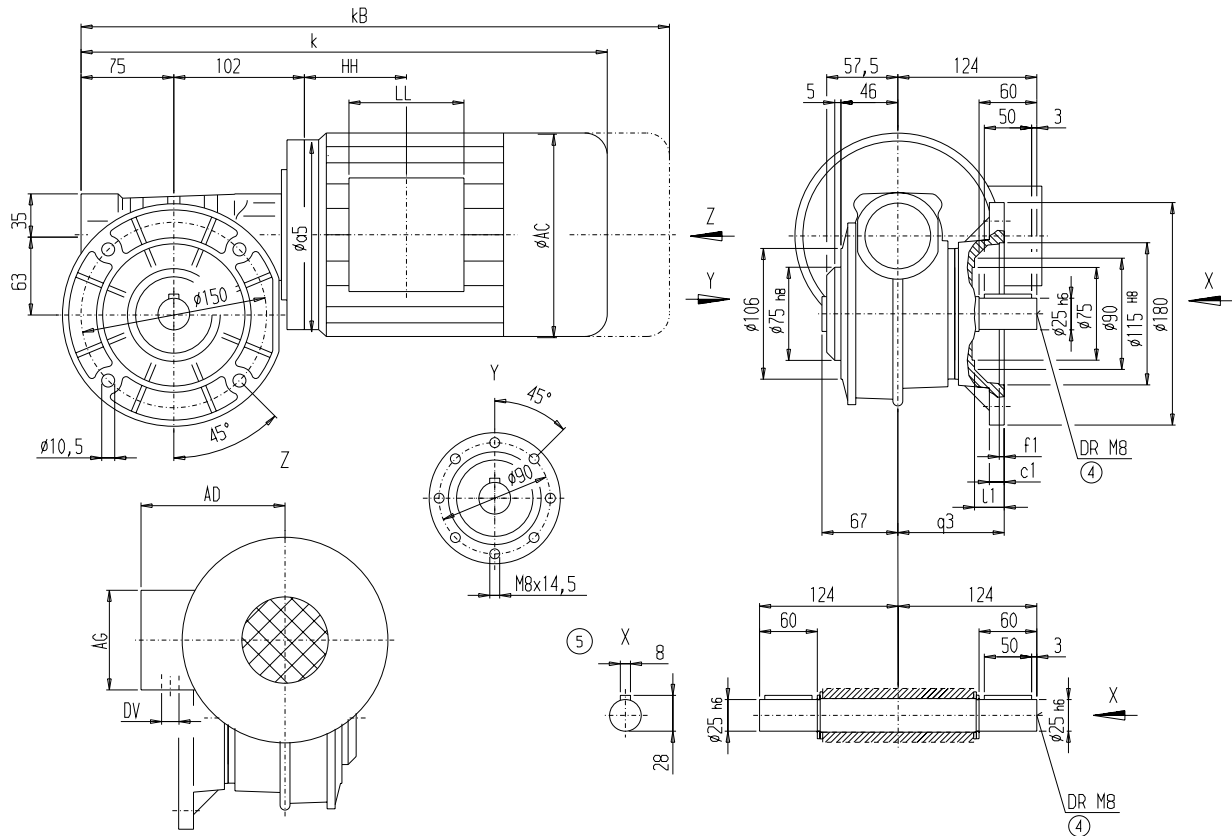

Flange	q3	l1	c1	f1
Short	86	24	12	4
Long	116	54	12	8

Motor	SCEF63		AC	AD	AG	LL	HH	a5		DV	Weight SCEF63
	k	k _B						IM-B14	IM-B5		
LA71	385.0	440	139.0	146	90	90	71.5	140	160	M20x1.5/M25x2.5	14
LA71Z	404.0	459	139.0	146	90	90	71.5	140	160	M20x1.5/M25x2.5	14
LA80	422.5	486	156.5	155	90	90	71.0	160	200	M20x1.5/M25x2.5	19
LA90S	469.0	540	174.0	163	90	90	86.5	160	200	M20x1.5/M25x2.5	23
LA90L	469.0	540	174.0	163	90	90	101.0	160	200	M20x1.5/M25x2.5	23
LA90ZL	514.0	585	174.0	163	90	90	101.0	160	200	M20x1.5/M25x2.5	26

© DIN 332

© Parallel key / keyway DIN 6885

Geared motors

Worm geared motors

Dimensions

Gear unit SCAZ63, shaft-mounted design with housing flange

SCAZ012

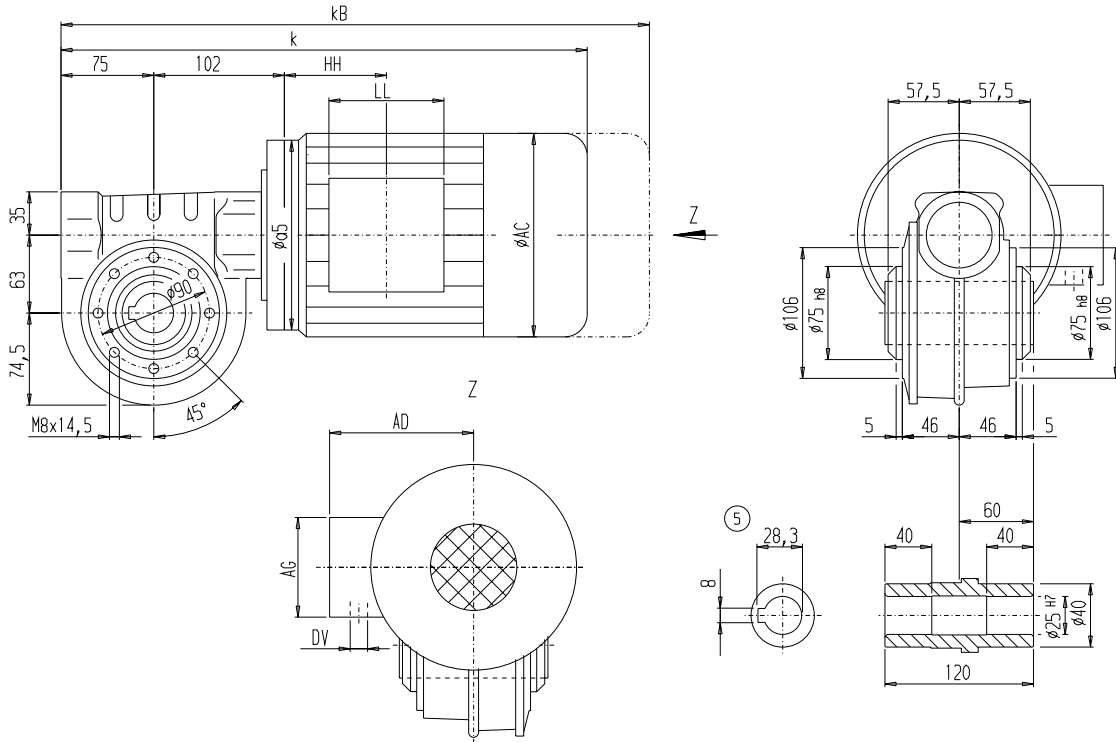

6

Motor	SCAZ63		AC	AD	AG	LL	HH	a5	IM-B5		DV	Weight SCAZ63
	k	kB							IM-B14	IM-B5		
LA71	385.0	440	139.0	146	90	90	71.5	140	160	M20x1.5/M25x2.5	12	
LA71Z	404.0	459	139.0	146	90	90	71.5	140	160	M20x1.5/M25x2.5	12	
LA80	422.5	486	156.5	155	90	90	71.0	160	200	M20x1.5/M25x2.5	17	
LA90S	469.0	540	174.0	163	90	90	86.5	160	200	M20x1.5/M25x2.5	21	
LA90L	469.0	540	174.0	163	90	90	101.0	160	200	M20x1.5/M25x2.5	21	
LA90ZL	514.0	585	174.0	163	90	90	101.0	160	200	M20x1.5/M25x2.5	24	

Ⓔ DIN 332

Ⓔ Parallel key / keyway DIN 6885

Gear unit SCAC63, shaft-mounted design, foot-mounted design "6 h"

SCAC012

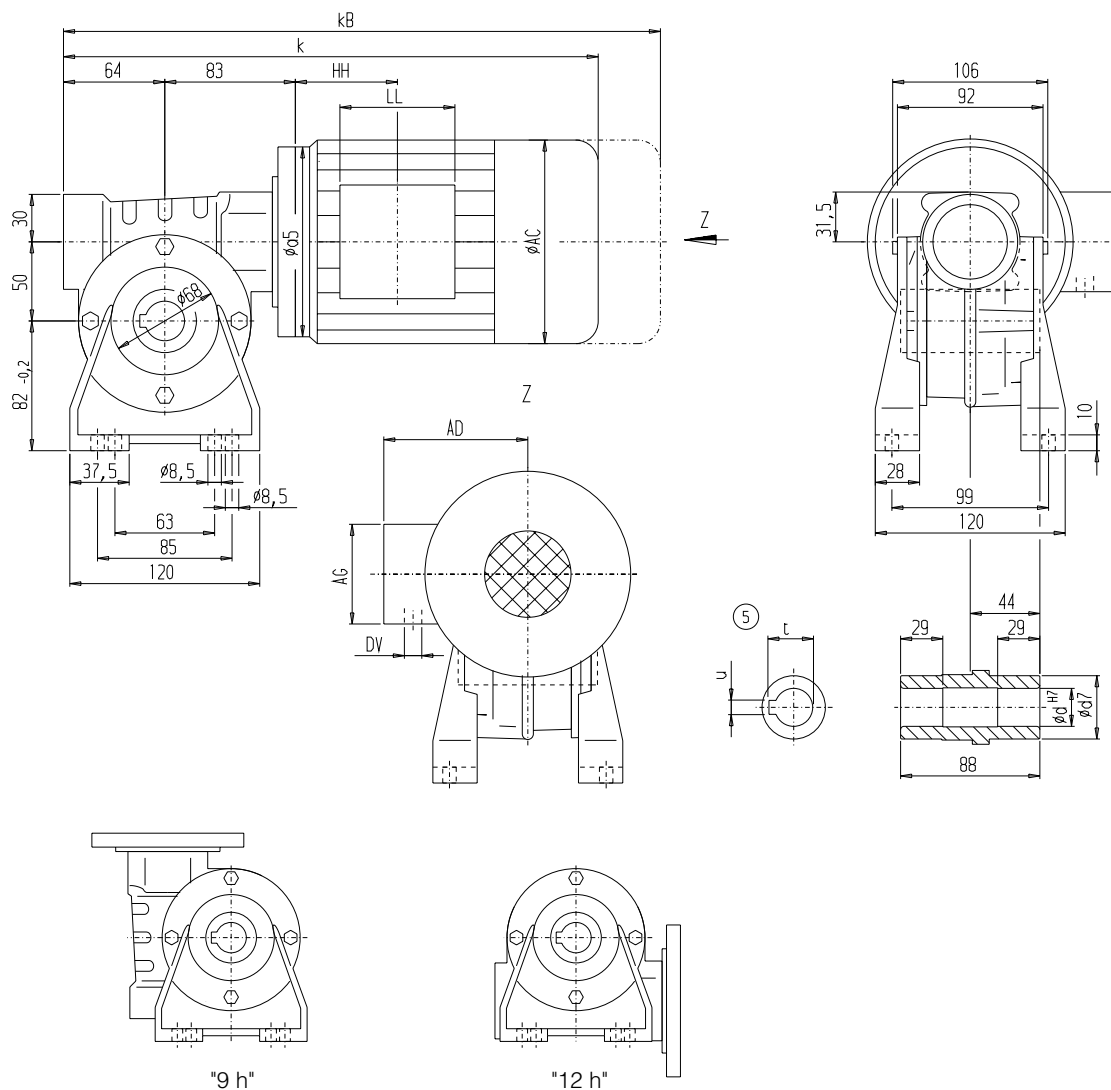

6

Motor	SCAC63		AC	AD	AG	LL	HH	a5		DV	Weight SCAC63
	k	kB						IM-B14	IM-B5		
LA71	385.0	440	139.0	146	90	90	71.5	140	160	M20x1.5/M25x2.5	13
LA71Z	404.0	459	139.0	146	90	90	71.5	140	160	M20x1.5/M25x2.5	13
LA80	422.5	486	156.5	155	90	90	71.0	160	200	M20x1.5/M25x2.5	18
LA90S	469.0	540	174.0	163	90	90	86.5	160	200	M20x1.5/M25x2.5	22
LA90L	469.0	540	174.0	163	90	90	101.0	160	200	M20x1.5/M25x2.5	22
LA90ZL	514.0	585	174.0	163	90	90	101.0	160	200	M20x1.5/M25x2.5	25

Geared motors

Worm geared motors

Dimensions

Gear unit SCAD63, shaft-mounted design with torque arm

SCAD012

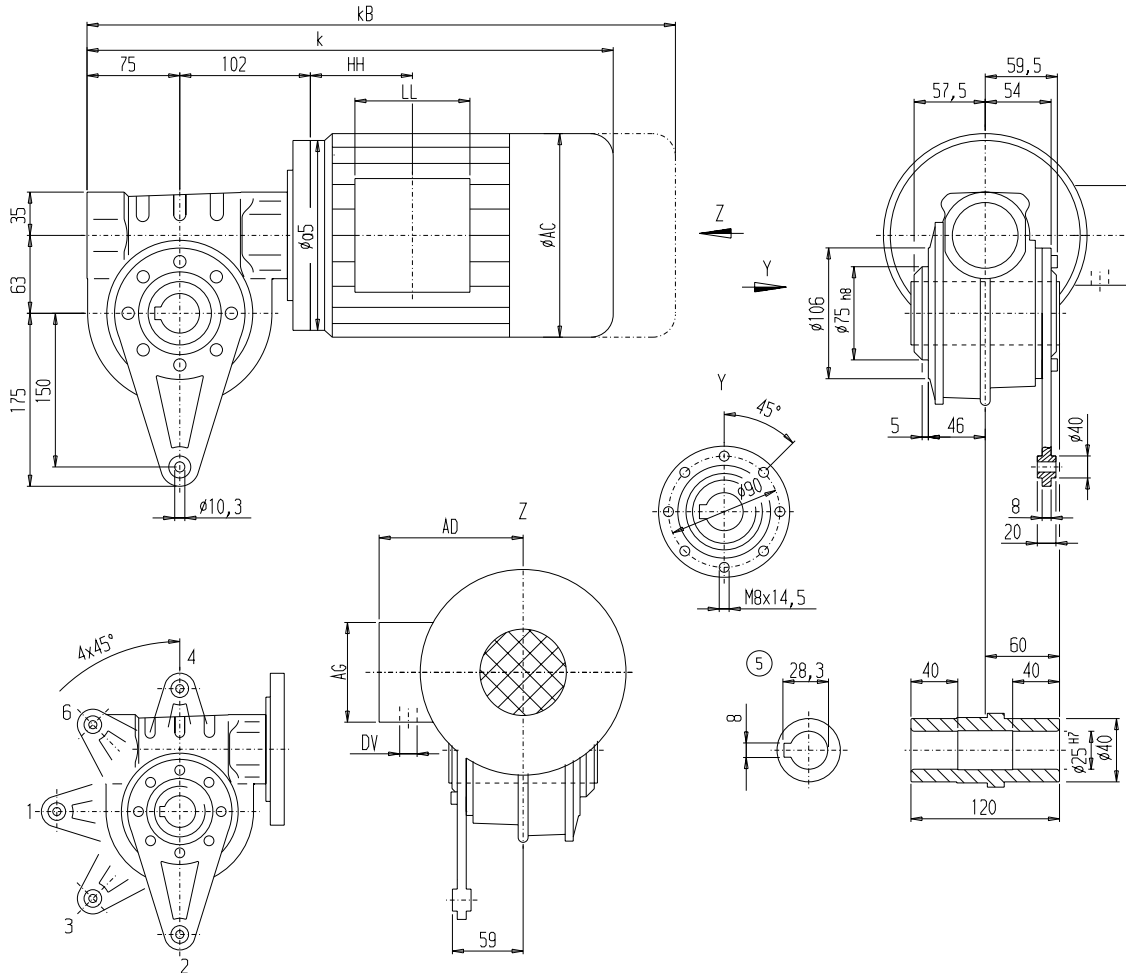

6

Motor	SCAD63										Weight SCAD63	
	k	k _B	AC	AD	AG	LL	HH	a5	IM-B14	IM-B5		DV
LA71	385.0	440	139.0	146	90	90	71.5	140	160	160	M20x1.5/M25x2.5	12
LA71Z	404.0	459	139.0	146	90	90	71.5	140	160	160	M20x1.5/M25x2.5	12
LA80	422.5	486	156.5	155	90	90	71.0	160	200	200	M20x1.5/M25x2.5	17
LA90S	469.0	540	174.0	163	90	90	86.5	160	200	200	M20x1.5/M25x2.5	22
LA90L	469.0	540	174.0	163	90	90	101.0	160	200	200	M20x1.5/M25x2.5	22
LA90ZL	514.0	585	174.0	163	90	90	101.0	160	200	200	M20x1.5/M25x2.5	25

© DIN 332

© Parallel key / keyway DIN 6885

Gear unit SCAF63, shaft-mounted design with flange

SCAF012

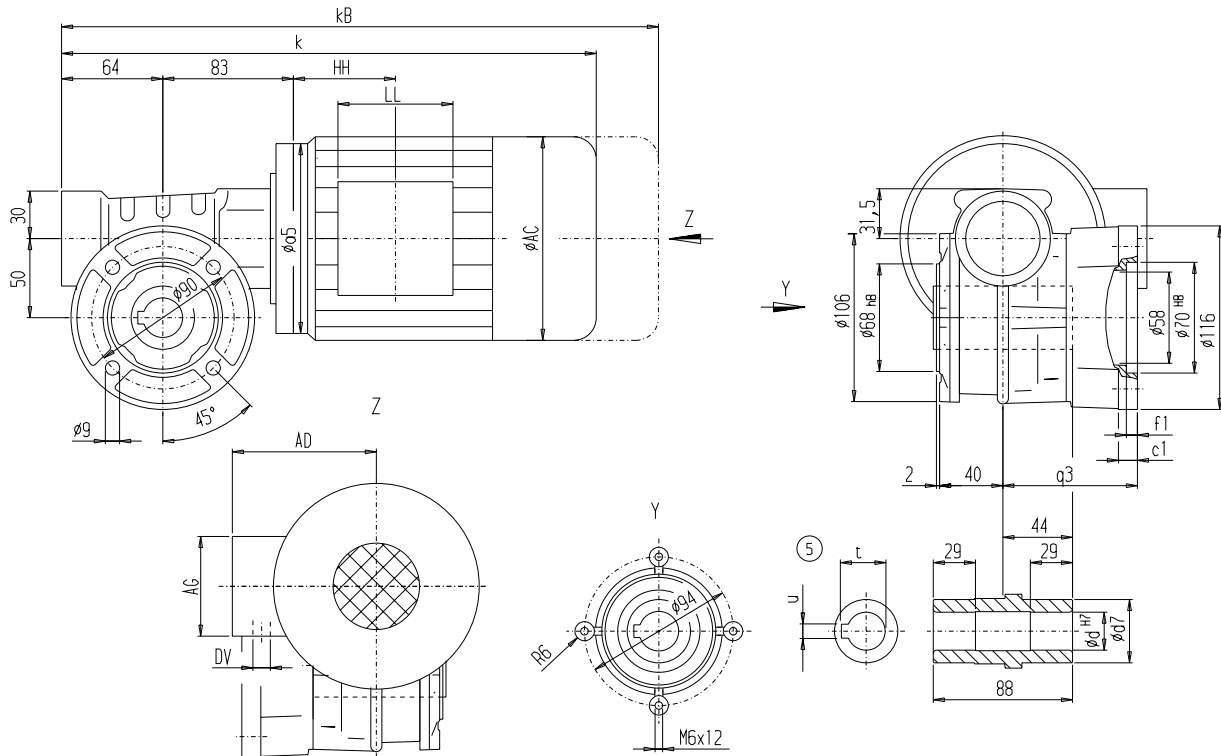

Flange	q3	l1	c1	f1
Short	86	24	12	4
Long	116	54	12	8

Motor	SCAF63		AC	AD	AG	LL	HH	a5		DV	Weight SCAF63
	k	kB						IM-B14	IM-B5		
LA71	385.0	440	139.0	146	90	90	71.5	140	160	M20x1.5/M25x2.5	14
LA71Z	404.0	459	139.0	146	90	90	71.5	140	160	M20x1.5/M25x2.5	14
LA80	422.5	486	156.5	155	90	90	71.0	160	200	M20x1.5/M25x2.5	19
LA90S	469.0	540	174.0	163	90	90	86.5	160	200	M20x1.5/M25x2.5	23
LA90L	469.0	540	174.0	163	90	90	101.0	160	200	M20x1.5/M25x2.5	23
LA90ZL	514.0	585	174.0	163	90	90	101.0	160	200	M20x1.5/M25x2.5	26

Geared motors

Worm geared motors

Dimensions

Gear unit with input flange (IM B5 or IM B14)

SC.-K4

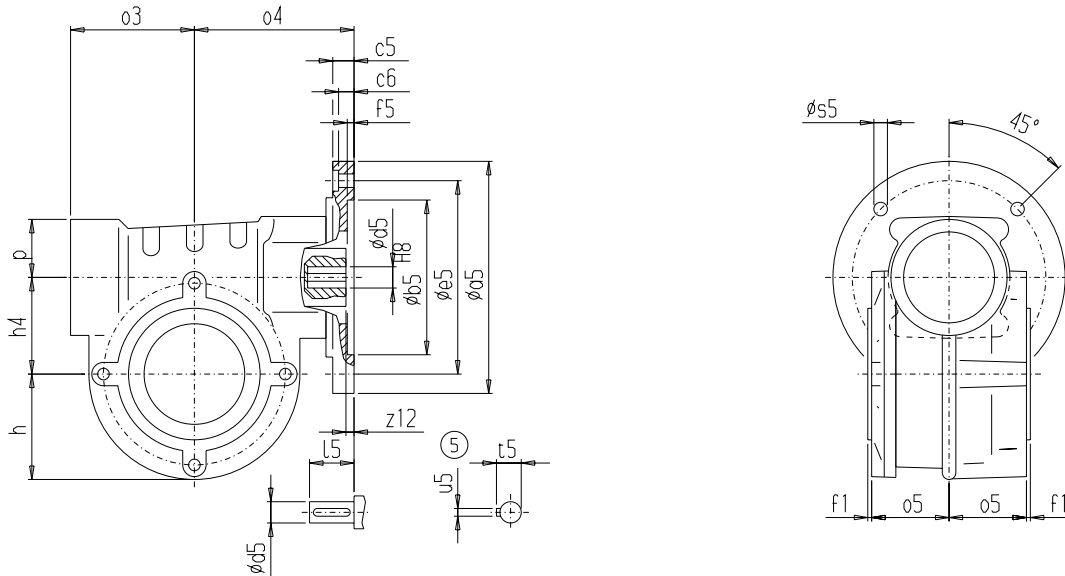

Gear unit type	Motor IM-B14	Motor IM-B5	a5	e5	b5	f5	c5	c6	z12	s5
SC36-K4	63	–	120	100	80	3.5	11.0	8.0	2	7
	71	63	140	115	95	3.5	11.0	9.0	2	9
SC50-K4	63	–	120	100	80	3.5	11.0	8.0	2	7
	71	63	140	115	95	3.5	11.0	9.0	2	9
	80/90	71	160	130	110	4.0	12.0	9.0	6	9
	–	80	200	165	130	4.0	13.5	9.5	6	11
SC63-K4	71	–	140	115	95	3.5	11.0	9.0	2	9
	80/90	71	160	130	110	4.0	12.0	9.0	6	9
	–	80/90	200	165	130	4.0	13.5	9.5	6	11

Gear unit type	Motor	d5	l5	u5	t5	o3	o4	p	h4	h	o5	f1
SC36-K4	63	11	23	4	12.5	44	67	18	36	44.0	35	2
	71	14	30	5	16.0							
SC50-K4	63	11	23	4	12.5	64	83	30	50	54.5	40	2
	71	14	30	5	16.0							
	80	19	40	6	21.5							
SC63-K4	71	14	30	5	16.0	75	102	35	63	74.5	46	5
	80	19	40	6	21.5							
	90	24	50	8	27.0							

Ⓒ DIN 332

Ⓒ Parallel key / keyway DIN 6885